

Installation Guide

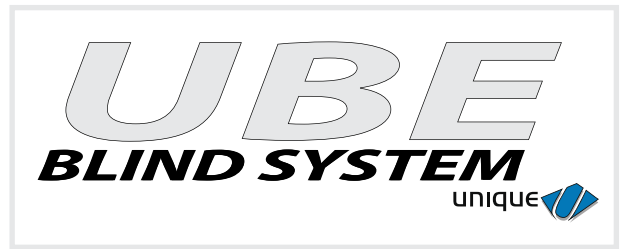

Thank you for purchasing the UBE Blind System for your outside area. The following instructions are a guide line only and no responsibility is accepted by Unique Covers and Tarps for the performance of this system. If installed correctly, the system will function as designed.

- 1) Decide whether the side channel will be face fit or recess mounted and measure opening (*Refer fig. 1 and 2*).

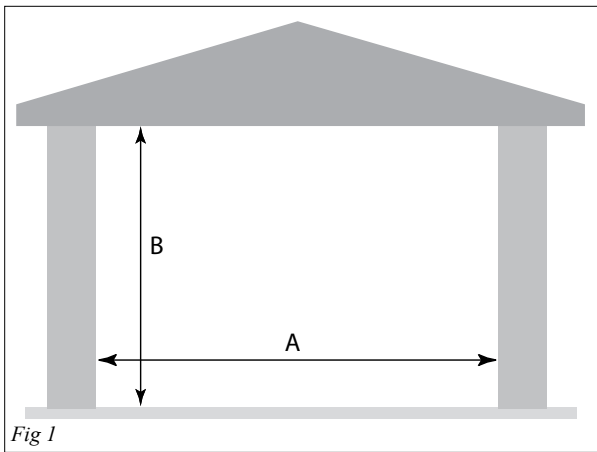

Fig 1

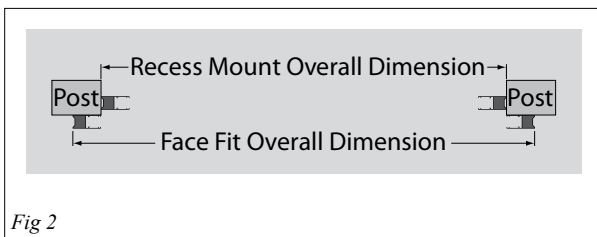

Fig 2

- 2) If using clear make sure it is of high quality. Cut clear to oversize and leave at least 24 hours to allow for shrinkage.
- 3) Cut side channel to length to measurement B (*fig. 1*).

If fabricating side channels please follow instructions 4 and 5

- 4) Notch the top of the side channel to suit the roller bracket (*fig. 3*).

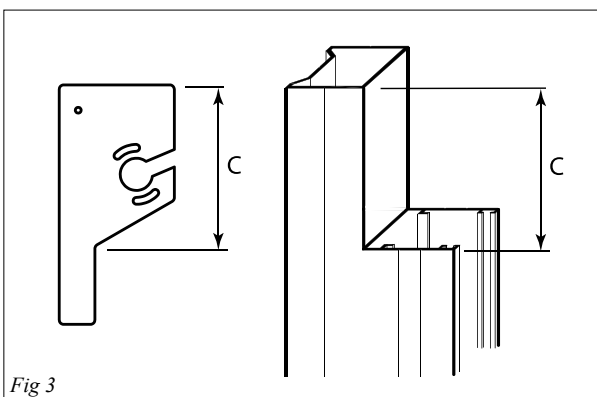

Fig 3

- 5) Slot bracket into recess in channel and rivet in place.
- 6) Cut roller tube to size, 105mm less than outside overall measurement.
- 7) Cut locking bar to size, 120mm less than outside overall measurement.
- 8) Drill holes in locking bar approximately 450mm from one end to take the lock (*fig. 4*).

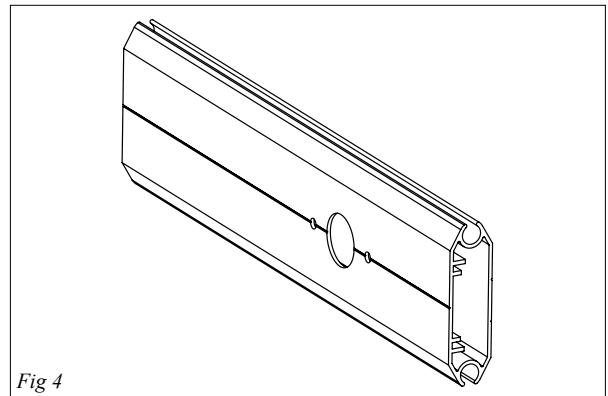

Fig 4

- 9) Fit lock rods into lock, insert into locking bar and fix with screws or rivets.
- 10) Slide in nylon end blocks and rivet.
- 11) Ensure lock is in the unlocked position and cut lock rods flush with end of locking bar.
- 12) Bolt gearbox onto roller bracket.
- 13) Drill hole in round shaft of end cap for split pin.
- 14) Cut curtain to size, 117mm less than outside overall measurement. Weld Keta strip to each side of curtain (*fig. 5*).

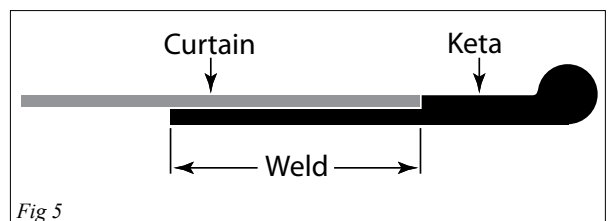

Fig 5

- 15) Attach 7mm rope, or keta to top and bottom of curtain and sew bottom corners.
- 16) Drill holes in side channel for fixing, drill through inside of channel for recess fixing and side of channel for face fixing. Make sure outer hole is large enough to fit the head of a tech screw through.
- 17) Cut 15 x 1.5mm equal angle 40mm shorter than side channel less the recess for roller bracket. Drill side channel and angle for fixing using a wedge between the angles to hold in place while drilling. Debur holes.
- 18) Place angles into locators in side channel leaving 40mm between bottom of angles and the bottom of the side channels & rivet into place
(Please Note: If powdercoating, powdercoat with angles in place to avoid gap for keta closing up, then remove when installing. You can just put a locator rivet top and bottom).
- 19) Slide felt into grooves in side channel.
- 20) Fit end caps and fabric to roller tube and locking bar to bottom of curtain.
- 21) Fit square end cap pin into gearbox and slot round shaft into bracket, insert nylon bush and split pin.
- 22) Slide locking bar into side channel lining up keta between angles on both sides.
- 23) Make sure everything is square and running smoothly, check gaps between angles.
- 24) Check lock rods extend correctly under bottom ends of insert channels when in the locked position.
- 25) Drive a 15mm screw or place a stay at the top of the side channel to stop the locking bar coming out of the top of the side channel when rolled up.
- 26) Hand over keys.

V1.0 - July 2010

UBE
BLIND SYSTEM
UNIQUE 



For more information

Phone **0800 625 111**

Auckland **Graeme.Obrien@mckechne.co.nz**

Central **Nathan.Brown@mckechne.co.nz**

Lower NI **Peter.Schmidt@mckechne.co.nz**

South Is. **Phil.Taylor@mckechne.co.nz**



Keeping the KIWI
lifestyle outdoors!