

Security & Grille

SECTION NUMBER	MASS kg/m	OUTSIDE PERIM	LENGTH
5663	0.351	143.50	5.00
5979	0.194	92.80	5.00
6136+	0.150	72.23	5.00
6179	0.450	194.42	5.00
30973	0.421	210.39	5.00
31701	0.589	230.62	6.00
33423 +	0.744	227.67	6.00
33627	0.483	217.96	4.60
33628	0.936	295.94	4.60
33629	0.483	217.75	4.60
33630 +	1.200	369.10	6.00
34689	1.521	453.62	4.60
38959 #	0.115	100.00	3.00
36405	0.154	87.09	3.00
37488	0.109	77.13	5.00
37523	0.804	237.92	6.00
G253	0.50	194.49	5.00
J007D +	1.022	320.58	5.00
K803	0.158	87.40	5.00
K804	0.106	56.70	5.00
K805	0.116	62.50	5.00
X574	0.249	126.32	5.00
Z340 +	0.751	240.51	6.00
Z785 +	0.748	240.25	5.00
Z785G	PUNCHED	RIGHT	3.00
Z785H	PUNCHED	LEFT	3.00

+ Also available in 3.0m lengths

Available in powder coat matt black only

DETAIL 'A'

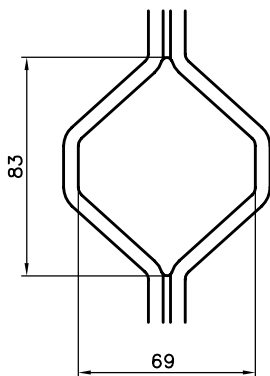

"007"
STYLE MESH

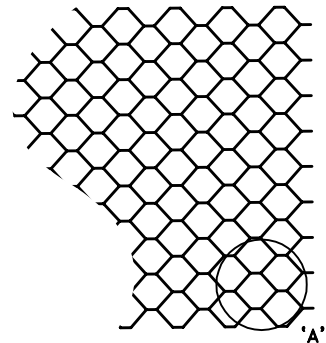

Hardware

ITEM NUMBER	DESCRIPTION
660000	DOOR HANDLE - WHITE
660001	DOOR HANDLE - BLACK
660002	5 PIN CYLINDER
660003	3 POINT LOCK KIT
660004	75mm DOOR HINGE - WHITE
660005	75mm DOOR HINGE - BLACK
660006	LEICHHARDT SLIDING DOOR LOCK
660007	WHEELS FOR SECURITY DOOR
660010	PATIO BOLT
661007	UBE LOCK
662107	WHEELS FOR 9775 FLYSCREEN DOOR

"007" STYLE SIZES	WAREHOUSE	
	NEW PLYMOUTH	CHRISTCHURCH
2000mm x 750mm	✓	✓
4000mm x 750mm	✓	✓
2000mm x 920mm	✓	✓
2455mm x 1200mm	✓	
2000mm x 1250mm	✓	✓
4000mm x 1250mm	✓	✓

CORNER STAKES	FITS SECTION
6868K	Z785, 33423
6868E	Z340
6868L	31701
X124G	5663, 6179
X124L	G253

For NZ based customers. All lengths are stocked in 6060 T5 - mill finish - 5m lengths (unless specified)
All peripheries less than 100mm are deemed 100mm for surface finish purpose

Security & Grille

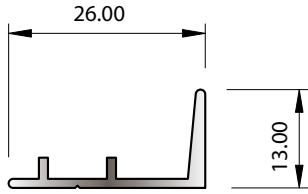

SECTION No. K803
0.158 kg/m
P = 87.40

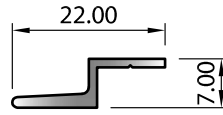

SECTION No. K804
ACCEPTS ANGLE 7084
0.106 kg/m
P = 56.70

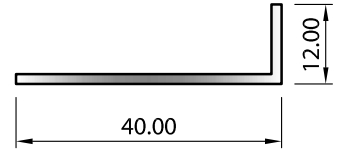

SECTION No. 7084
0.205 kg/m
P = 104

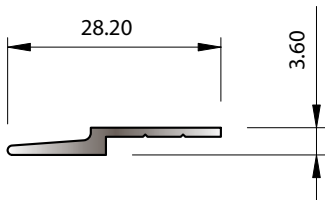

SECTION No. K805
0.116 kg/m
P = 62.50

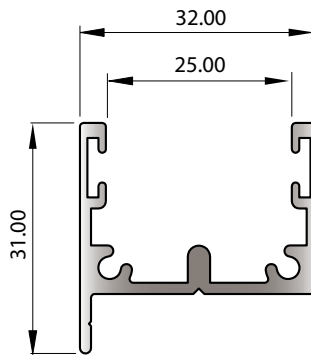

SECTION No. 33627
0.483 kg/m
P = 217.96
LENGTH = 4.6m

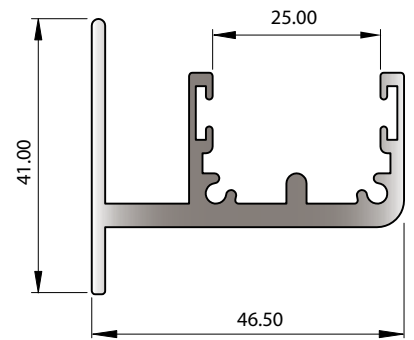

SECTION No. 33628
0.936 kg/m
P = 295.94
LENGTH = 4.6m

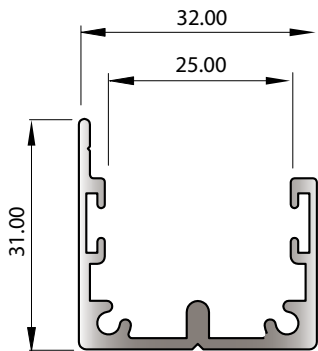

SECTION No. 33629
0.483 kg/m
P = 217.75
LENGTH = 4.6m

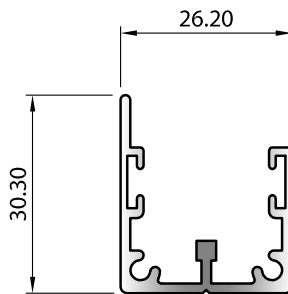

SECTION No. 30973
0.421 kg/m
P = 210.39

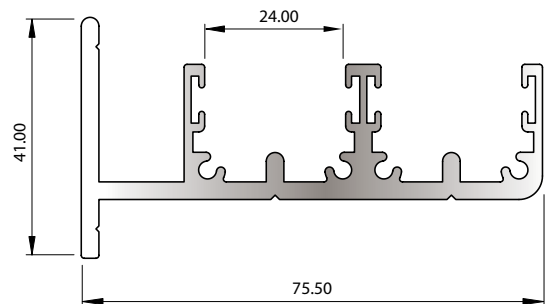

SECTION No. 34689
1.521 kg/m
P = 453.62
LENGTH = 4.6m

For NZ based customers. All lengths are stocked in 6060 T5 - mill finish - 5m lengths (unless specified)
All peripheries less than 100mm are deemed 100mm for surface finish purpose

Security & Grille

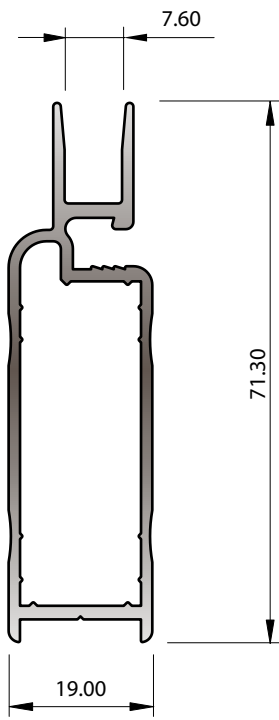

SECTION No. 33423
ACCEPTS STAKING ANGLE 6868K
0.744 kg/m
P = 227.67

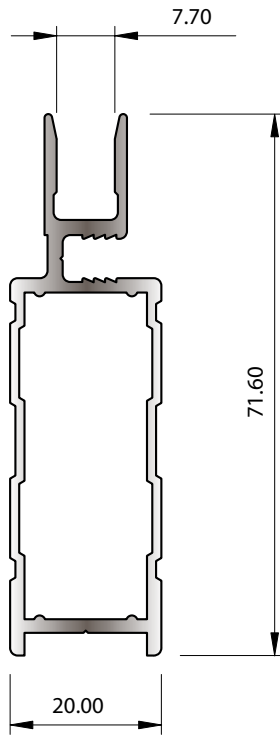

SECTION No. Z340
ACCEPTS STAKING ANGLE 6868E
0.751 kg/m
P = 240.51

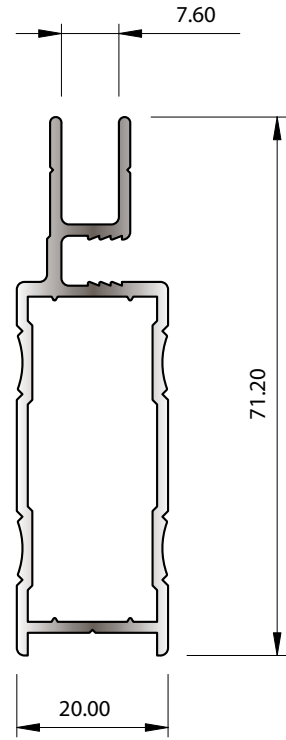

SECTION No. Z785
ACCEPTS STAKING ANGLE 6868K
0.748 kg/m
P = 240.25

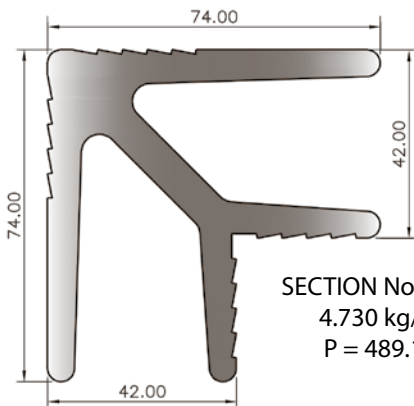

SECTION No. 6868
4.730 kg/m
P = 489.18

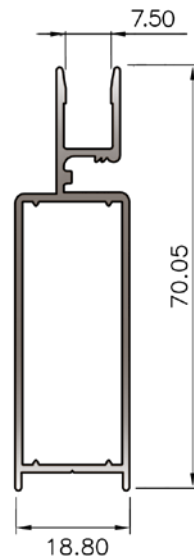

SECTION No. 31701
0.589 kg/m
P = 230.62
ACCEPTS STAKING ANGLE 6868L

For NZ based customers. All lengths are stocked in 6060 T5 - mill finish - 5m lengths (unless specified)
All peripheries less than 100mm are deemed 100mm for surface finish purpose

Security & Grille

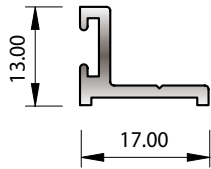

SECTION No. 6136
0.150 kg/m
P = 72.23

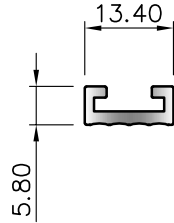

SECTION No. 38959
0.115 kg/m
P = 100

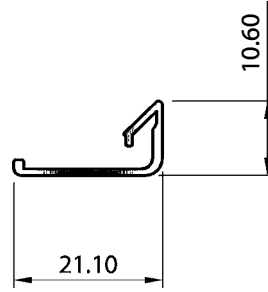

SECTION No. 37488
0.109 kg/m
P = 77.13

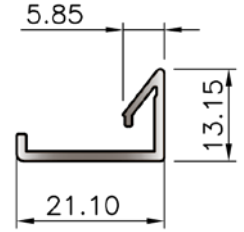

SECTION No. 36405
0.154 kg/m
P = 87.09

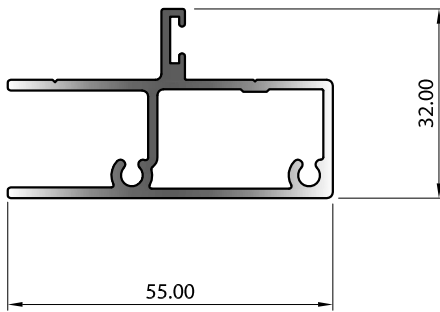

SECTION No. 37523
0.804 kg/m
P = 237.92

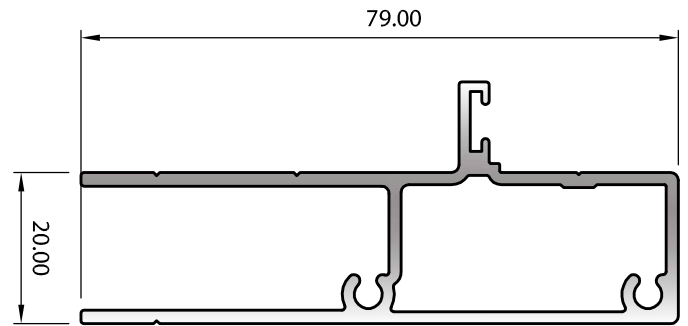

SECTION No. J007D
1.022 kg/m
P = 320.58

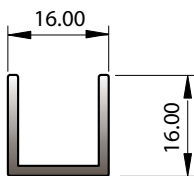

SECTION No. 5979
0.194 kg/m
P = 92.80

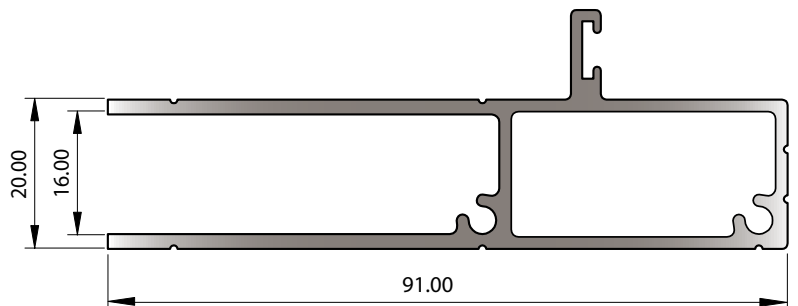

SECTION No. 33630
1.200 kg/m
P = 369.10

For NZ based customers. All lengths are stocked in 6060 T5 - mill finish - 5m lengths (unless specified)
All peripheries less than 100mm are deemed 100mm for surface finish purpose

Security & Grille

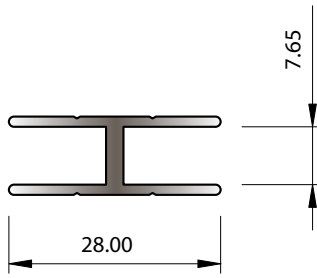

SECTION No. X574
0.249 kg/m
P = 126.32

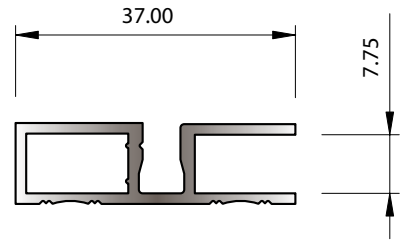

SECTION No. 5663
ACCEPTS STAKING ANGLE X124G
0.351 kg/m
P = 143.50

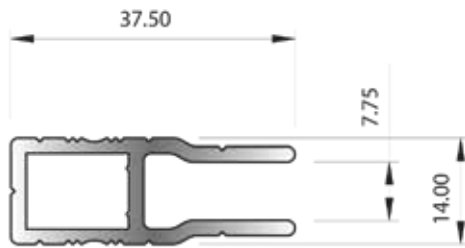

SECTION No. G253
ACCEPTS STAKING ANGLE X124L
0.500 kg/m
P = 194.49

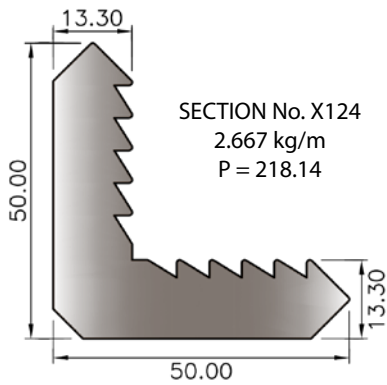

SECTION No. X124
2.667 kg/m
P = 218.14

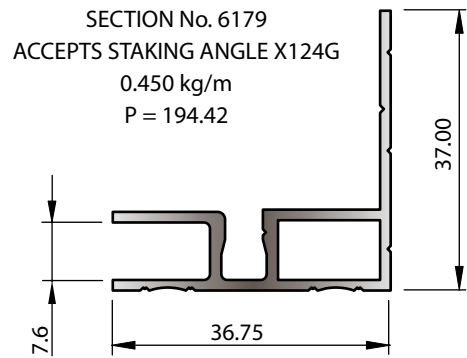

SECTION No. 6179
ACCEPTS STAKING ANGLE X124G
0.450 kg/m
P = 194.42

For NZ based customers. All lengths are stocked in 6060 T5 - mill finish - 5m lengths (unless specified)
All peripheries less than 100mm are deemed 100mm for surface finish purpose