

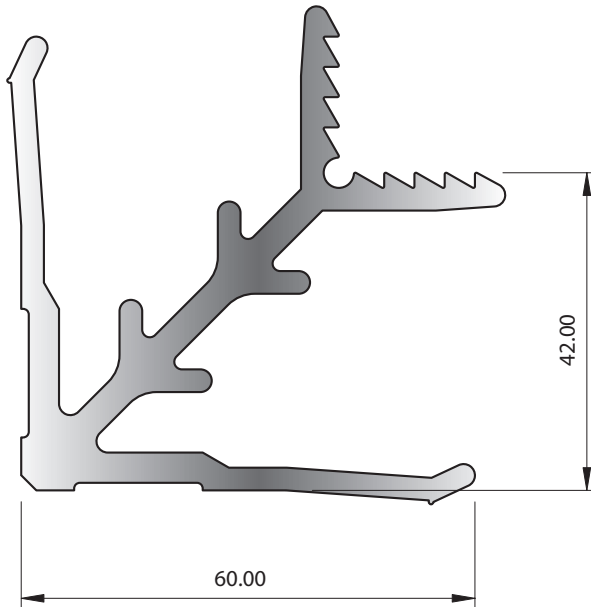

McKechnie®  
Transforming Aluminium

## Staking Angles Group 4.3.1



SECTION No. 6256  
TO FIT WITH SECTION No. K067 & 6867  
2.278 kg/m  
P = 464.16

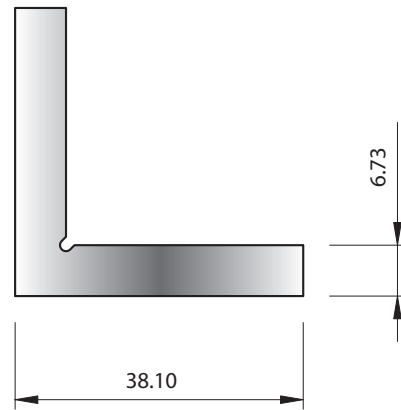

SECTION No. 2075  
1.258 kg/m  
P = 155

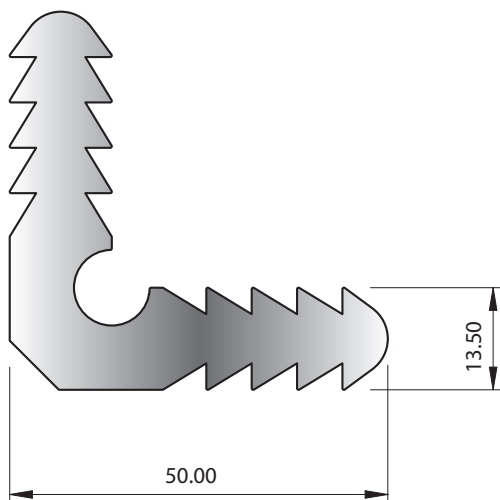

SECTION No. 6180  
TO FIT WITH SECTION No. 5663  
2.352 kg/m  
P = 268

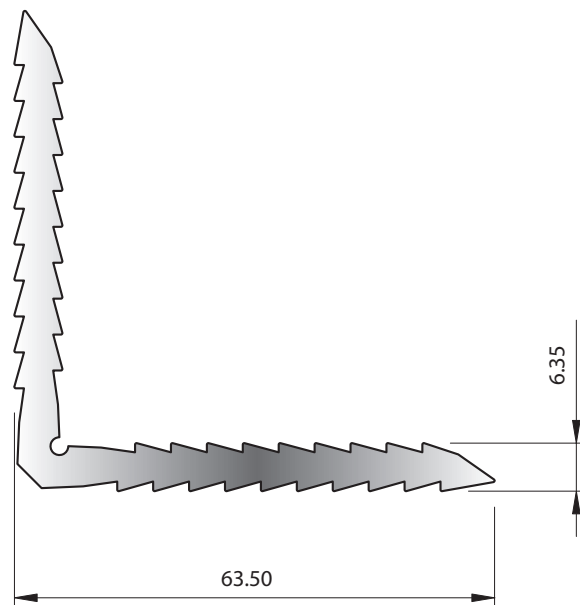

SECTION No. 9126  
1.582 kg/m  
P = 296



# Staking Angles Group 4.3.2

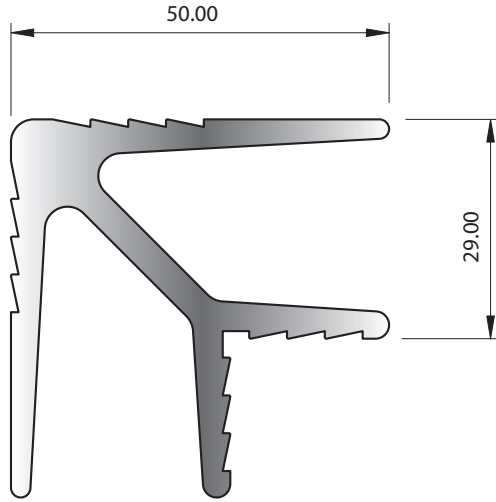

SECTION No. J688\*  
TO FIT WITH SECTION No. 9775  
1.747 kg/m  
P = 338.30

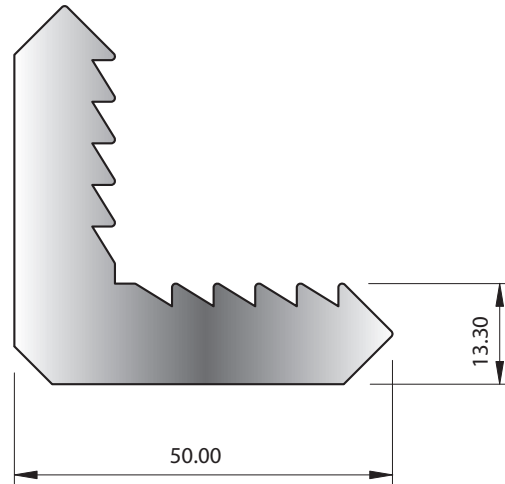

SECTION No. X124\*  
TO FIT WITH SECTION No. 5663, N775 & X817  
2.666 kg/m  
P = 218.14

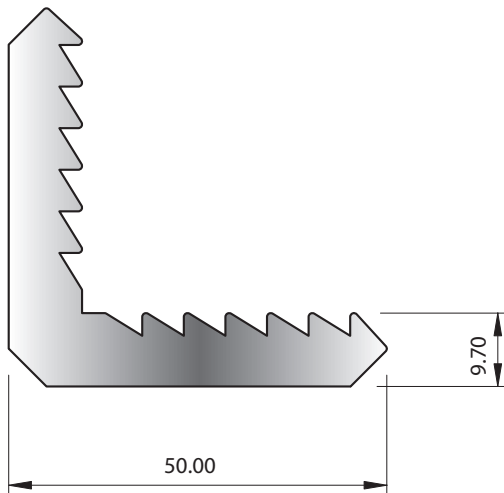

SECTION No. X372\*  
TO FIT WITH SECTION No. X511  
1.987 kg/m  
P = 229.84

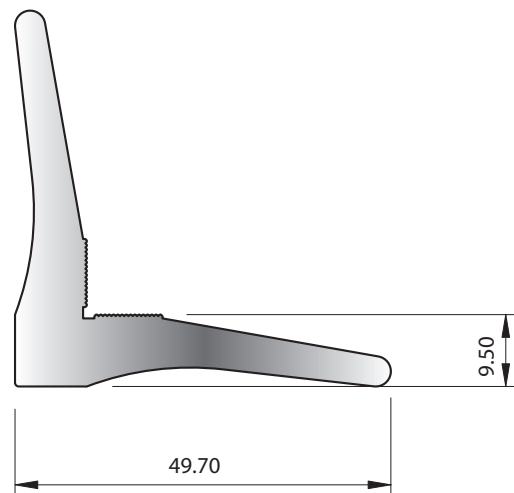

SECTION No. X429  
TO FIT WITH SECTION No. J058  
1.475 kg/m  
P = 192.90

\* SOME SPECIAL TOLERANCES APPLY



McKechnie®  
Transforming Aluminium

## Staking Angles Group 4.3.3

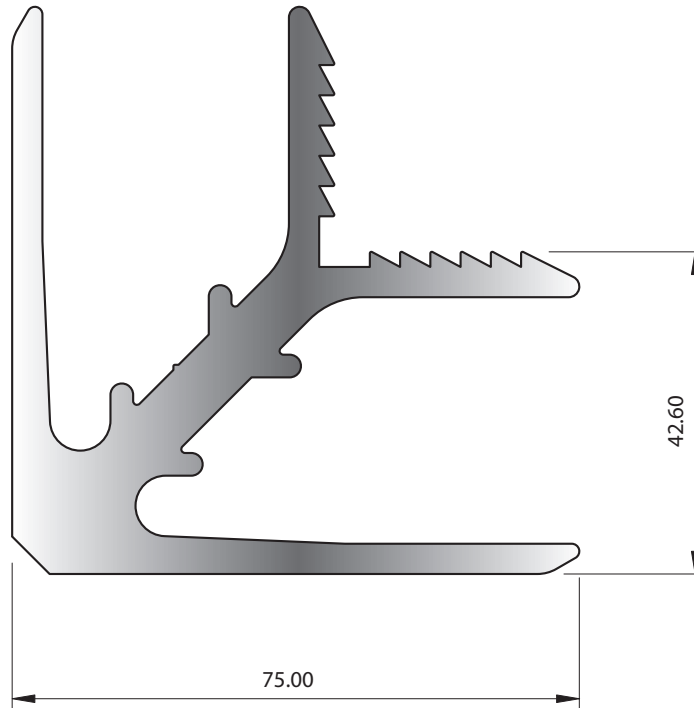

SECTION No. X390\*  
3.825 kg/m  
P = 539.66

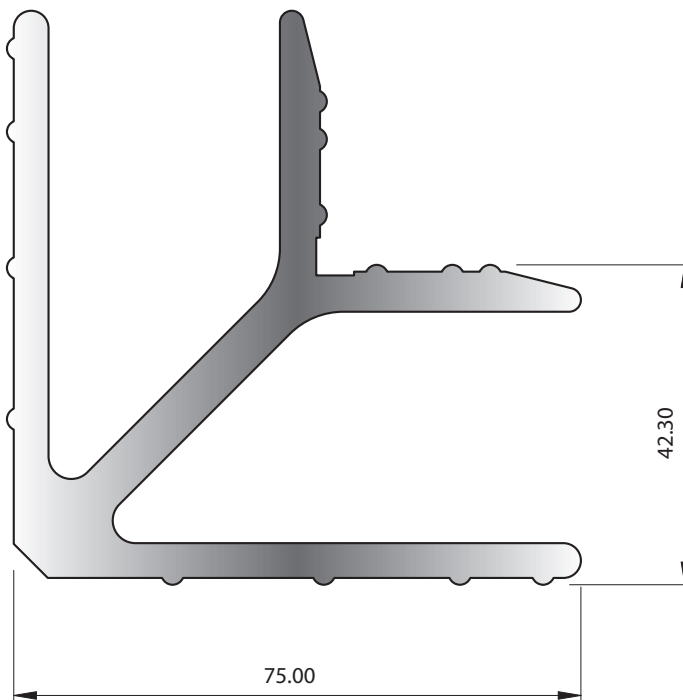

SECTION No. N637\*  
TO FIT WITH SECTION No. K067, K144  
3.598 kg/m  
P = 512.22

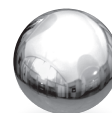

McKechnie®  
Transforming Aluminium

# Staking Angles Group 4.3.4

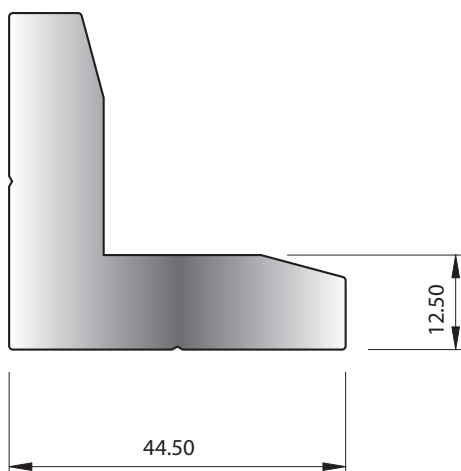

SECTION No. G463\*  
2.498 kg/m  
P = 172.35

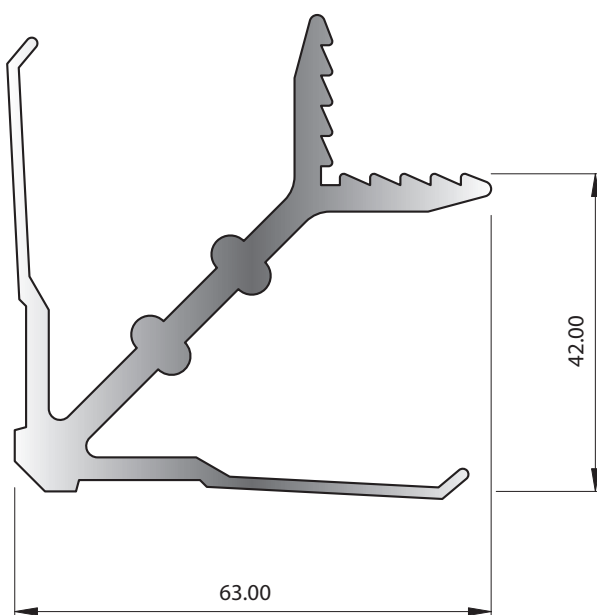

SECTION No. G465\*  
1.828 kg/m  
P = 438.33

\* SOME SPECIAL TOLERANCES APPLY



McKechnie®  
Transforming Aluminium

# Staking Angles Group 4.3.5

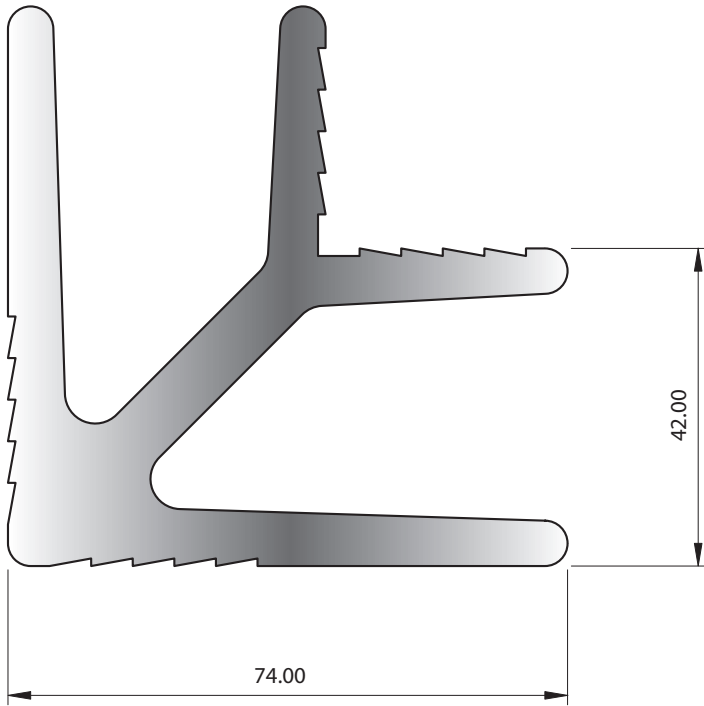

SECTION No. 6868\*  
4.730kg/m  
P = 489.18

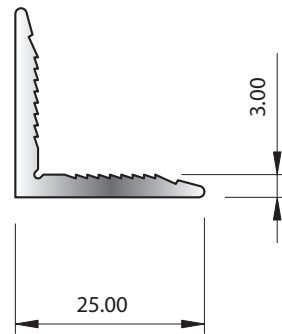

SECTION No. 6497  
0.329 kg/m  
P = 108

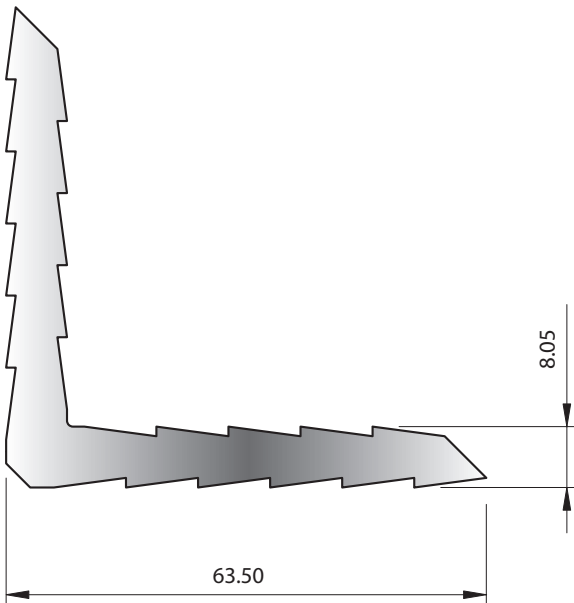

SECTION No. 1528  
2.093 kg/m  
P = 265

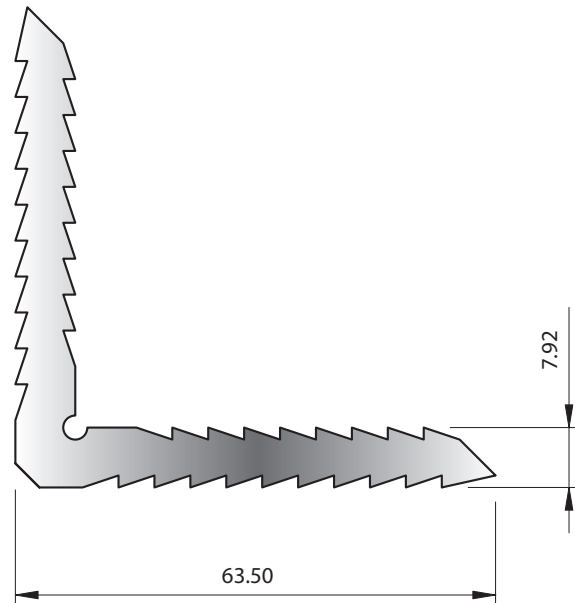

SECTION No. 1754  
1.999 kg/m  
P = 312

Staking Angles Group 4.3.5

\* SOME SPECIAL TOLERANCES APPLY