

Internal Glazing

SECTION NUMBER	MASS kg/m	OUTSIDE PERIM	LENGTH	STOCKED IN ANODISED
33602	0.353	178.41	5.00	
33603	0.278	141.75	5.00	
33604	0.742	275.99	5.00	
33605	0.160	91.28	5.00	
5620	0.484	157.03	5.00	CHCH ONLY
5653	0.166	97.50	5.00	✓
Z661+	0.184	114.92	5.60	✓
Z662+	0.442	207.66	5.60	✓

+ Stocked in anodised finish only

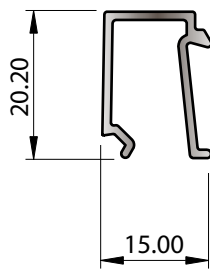

SECTION No. Z661
0.184 kg/m
P = 114.92

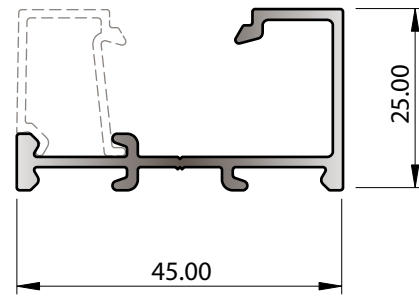

SECTION No. Z662
0.442 kg/m
P = 207.66

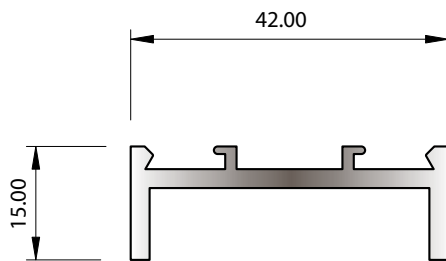

SECTION No. 5620
0.484 kg/m
P = 157.03

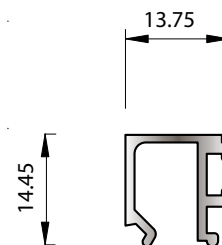

SECTION No. 5653
0.166 kg/m
P = 97.50

For NZ based customers. All lengths are stocked in 6060 T5 - mill finish - 5m lengths (unless specified)
All peripheries less than 100mm are deemed 100mm for surface finish purpose

Internal Glazing

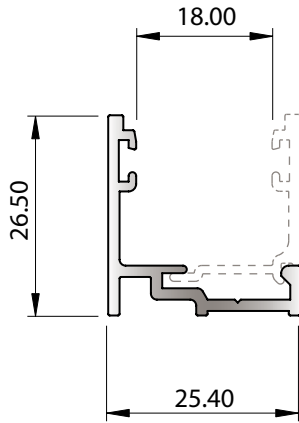

SECTION No. 33603
0.278 kg/m
P = 141.75

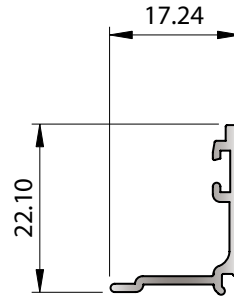

SECTION No. 33605
0.160 kg/m
P = 91.28

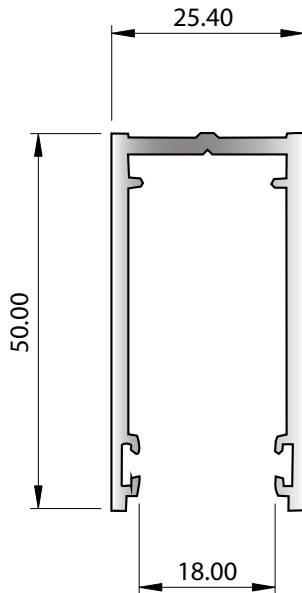

SECTION No. 33604
0.742 kg/m
P = 275.99

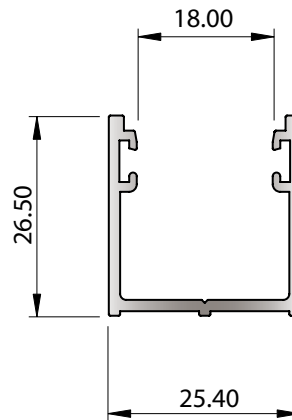

SECTION No. 33602
0.353 kg/m
P = 178.41

For NZ based customers. All lengths are stocked in 6060 T5 - mill finish - 5m lengths (unless specified)
All peripheries less than 100mm are deemed 100mm for surface finish purpose