



McKechnie® Sections Stocked Products

McKechnie®
Transforming Aluminium

Standard Geometric Sections
Commercial Suites
Building Products

updated April 2024



Contacts

NZ WIDE ORDERS & CUSTOMER SERVICE	PHONE	0800 625 111
	FAX	0800 733 755
	EMAIL	distribution@mckechnie.co.nz

REGIONAL OFFICES:

AUCKLAND:	PHONE	(09) 272 6060
------------------	-------	---------------

WELLINGTON:	PHONE	(027) 456 5566
--------------------	-------	----------------

CHRISTCHURCH:	PHONE	(03) 339 2607
	FAX	(03) 338 5470

WAIKATO /

BAY OF PLENTY:	PHONE	(027) 495 9971
-----------------------	-------	----------------

NEW PLYMOUTH: (Manufacturing Base)	ADDRESS	36 Paraitē Road, Bell Block, New Plymouth 4372
	PHONE	(06) 755 9900
	FAX	(06) 755 9924

McKechnie® Aluminium is Australasia's leading integrated aluminium extrusion specialist. We focus on delivering precision-engineered components that fit seamlessly into our customer's products. We build strong partnerships with our customers and are able to take on challenges and imagine solutions that others can't. Contact McKechnie® Aluminium for all your aluminium extrusion, surface finishing and fabrication requirements.

PLEASE NOTE:

All sections shown in this catalogue are standard extrusion sections, available for New Zealand based customers. For any custom-made requirements, please contact us directly on 0800 625 000.

This catalogue lists extrusion sections available ex-stock only, however, stocked items may change due to market demands. Standard geometric sections are available in 5 metre lengths, 6060 alloy, unless specified. Pacific commercial door and shopfront are available in standard industry lengths, 6060 alloy.

Some sections may be held ex-stock in anodised natural or powder coated. Sections that are not held in surface finish can be powder coated or anodised and despatched within 5 working days from receipt of order.

www.mckechnie.co.nz

Copyright © Terms of Use

McKechnie® Aluminium Solutions Limited makes this Catalogue available for the general use and reference of customers. In doing so, all use of the Catalogue is governed by these terms of use. Copyright in this Catalogue and, where applicable intellectual property rights in any proprietary products and systems contained, are reserved in all respects to McKechnie® Aluminium Solutions Ltd. No copying, appropriation or modification of this Catalogue, or use of any proprietary products and systems, is permitted without express written consent of McKechnie® Aluminium Solutions Ltd. All registered trademark rights in the name "McKechnie®" and logo are reserved to McKechnie® Aluminium Solutions Ltd. All information contained in this Catalogue should be considered for general information only. While great care has been taken to ensure the information contained is complete and accurate this Catalogue does not constitute an offer by McKechnie® Aluminium Solutions Ltd to sell or supply any item nor that an item will at all times be available for supply. McKechnie® Aluminium Solutions Ltd reserves the right at any time to cease supply of items (whether permanently or temporarily) and/or to alter the specifications or nature of any item contained in the Catalogue. A customer must always specifically enquire at McKechnie® to determine whether any item required is available and in the form required by the customer. Any order by a customer will always be subject to the Terms of Trade in use from time to time by McKechnie® Aluminium Solutions Ltd. McKechnie® Aluminium Solutions Ltd accepts no liability or responsibility for any loss, damage, cost or expense in any form suffered by any person and which results from any error or omission in this Catalogue or as a result of any inability to supply an item from this Catalogue for any reason (whether temporary or permanent). McKechnie® further excludes any representation or warranty that the items in the Catalogue are fit or suitable for any particular purpose and on each occasion a customer must order items solely in reliance on their own judgment.

© McKechnie Aluminium Solutions Ltd (2009-2024).

Contents

FOR NZ BASED CUSTOMERS

■ **Standard Geometric Sections**

■ Equal Angles	1
■ Unequal Angles	2
■ Channels	3 - 4
■ Flats	5 - 6
■ Hollows - Square	7
■ Hollows - Rectangular	8
■ Solid Rods	9
■ Extruded Tubes	10
■ Tees, Solid Squares & Other	11

■ **Commercial Suites**

■ Pacific Commercial Door	13 - 18
■ Pacific Shopfront 75 Series	19 - 22
■ Pacific Shopfront 100 Series	23 - 26
■ Coolstore	27 - 31

■ **Building Products**

■ Wardrobe Suites	33 - 36
■ Internal Glazing	37 - 38
■ Head Flashings, Sill Pans & Adaptors	39
■ WANZ Sill Support Bars	40
■ Retrofit Double Glazing	41 - 43
■ Security & Grille	44 - 48
■ Flyscreen	49 - 51
■ Awning	52 - 53
■ Miscellaneous	54 - 55
■ Fence and Balustrade	56 - 58

■ Index	59 - 64
----------------------	---------

Equal Angles

SECTION NUMBER	A	T	R	MASS kg/m	OUTSIDE PERIM	STOCKED IN ANODISED
6421	12.00	1.65		0.100	48.00	✓
5968	12.00	3.00		0.170	48.00	
5766	15.00	1.50		0.115	60.00	
G466	16.00	1.60		0.132	64.00	
5512	20.00	1.60		0.167	80.00	
5972	20.00	3.00		0.300	80.00	✓
5510	25.00	1.60		0.210	100.00	
5973	25.00	3.00		0.381	100.00	
5011	25.40	4.50		0.565	100.60	
5014 ⁺	25.40	6.00		0.703	101.60	
5006	31.75	3.00		0.492	127.00	✓
0572	31.75	4.75		0.753	127.00	
K014	32.00	1.50		0.254	128.00	
5975	40.00	1.60		0.333	160.00	
5976	40.00	3.00		0.624	160.00	
K129	40.00	4.00		0.824	160.00	
9530	40.00	6.00		1.199	160.00	
6484	50.00	1.60		0.425	200.00	
5977	50.00	3.00		0.786	200.00	
J792	50.00	4.00		1.040	200.00	
8518	50.00	6.00		1.523	200.00	
9743	60.00	3.00		0.948	240.00	
9780	60.00	6.00		1.847	239.50	
30543	75.00	6.00		2.341	300.00	
5009	76.20	3.00		1.210	304.80	
5018 ⁺	76.20	6.00		2.372	304.80	
5424	76.20	9.00		3.485	304.80	
31708	100.00	6.00		3.154	400.00	
1025	101.60	6.35		3.423	402.50	
1908	101.60	9.53	9.14	5.055	402.48	

+ Stocked in Christchurch warehouse only

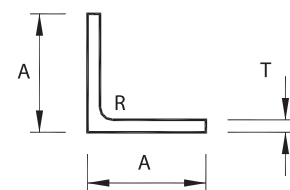
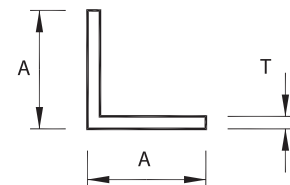

Unequal Angles

SECTION NUMBER	A	B	T	R	MASS kg/m	OUTSIDE PERIM	STOCKED IN ANODISED
5514	20.00	12.00	1.60		0.132	64.00	✓
5970	20.00	12.00	3.00		0.235	64.00	
9325	25.00	12.00	1.50		0.144	74.00	✓
5971	25.00	12.00	3.00		0.275	74.00	
5511	25.00	20.00	1.60		0.188	90.00	
J074	25.00	20.00	3.00		0.341	90.00	
5931	30.00	25.00	2.00		0.286	109.57	
0460	32.00	19.00	3.00		0.388	102.00	
9328	32.00	20.00	1.50		0.205	104.00	
5974	32.00	25.00	3.00		0.437	114.00	
6670	38.00	19.00	1.60		0.239	114.00	
7084	40.00	12.00	1.50		0.205	104.00	
9745	40.00	12.00	3.00		0.397	104.00	
9329	40.00	20.00	1.50		0.237	120.00	
8459	40.00	20.00	1.60		0.252	120.00	✓
6076	40.00	20.00	3.00		0.462	120.00	✓
5509	40.00	25.00	1.60		0.275	130.00	✓
8517	40.00	25.00	3.00		0.502	130.00	
J456	50.00	20.00	1.50		0.278	140.00	
31043	50.00	20.00	3.00		0.545	140.00	
5903	50.00	25.00	1.60		0.317	150.00	
5323	50.00	25.00	3.00		0.585	150.00	
9753	60.00	25.00	3.00		0.664	170.00	
6428	70.00	25.00	1.60		0.403	190.00	✓
Z965	70.00	40.00	1.60		0.470	220.00	
J105	70.00	40.00	2.00		0.585	220.00	
30193	75.00	25.00	3.00		0.789	200.00	
6788	75.00	50.00	3.00		0.988	250.00	
1658	76.20	50.80	4.75	6.86	1.601	251.06	
2386	76.20	50.80	6.35		2.085	254.00	
34033	80.00	40.00	3.00		0.951	240.00	
8266	100.00	25.00	3.00		0.992	250.00	
30641	100.00	50.00	3.00		1.195	300.00	
E927	100.00	50.00	6.00		2.341	300.00	
33919	150.00	75.00	6.00		3.561	450.00	
2601	152.40	76.20	6.35		3.810	457.20	

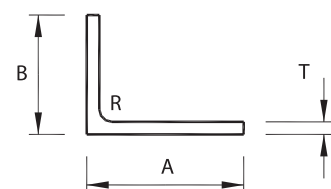
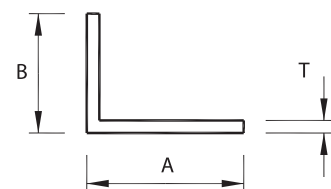

For NZ based customers. All lengths are stocked in 6060 T5 - mill finish - 5m lengths (unless specified)
All peripheries less than 100mm are deemed 100mm for surface finish purpose

Channels

SECTION NUMBER	A	B	T1	T2	R	MASS kg/m	OUTSIDE PERIM	STOCKED IN ANODISED
J168	10.00	10.00	1.60	1.60		0.116	56.80	
5978	12.00	12.00	1.60	1.60		0.142	68.80	CHCH ONLY
0371	12.70	12.70	2.54	2.54		0.226	71.10	
0765	14.15	11.89	1.52	1.52		0.143	72.80	
X075	14.50	17.95	1.25	1.25		0.162	98.63	
660154~	15.00	18.00	1.80	1.80		0.230	100.00	BRIGHT ONLY
660155#	15.00	18.00	1.80	1.80		0.230	100.00	BRIGHT ONLY
5979	16.00	16.00	1.60	1.60		0.194	92.80	
660022~	17.60	18.40	1.80	1.80		0.246	100.00	BRIGHT ONLY
660023#	17.60	18.40	1.80	1.80		0.246	100.00	BRIGHT ONLY
5980	20.00	20.00	3.00	3.00		0.437	115.00	
0382+	20.65	19.84	1.98	1.98	1.59	0.305	146.80	
9335	25.00	25.00	1.60	1.60		0.310	147.00	
4575	25.00	25.00	3.00	3.00		0.559	144.00	✓
6476	25.00	40.00	3.00	3.00		0.801	204.00	
4087	25.00	50.00	3.00	3.00		0.161	79.40	
1770	28.58	6.35	1.57	1.57		0.164	100.00	
J088	32.00	25.00	3.00	3.00		0.618	158.00	
G210	36.00	36.00	2.50	2.50		0.698	211.00	
33465	40.00	12.00	3.00	3.00		0.472	122.00	✓

~ Stocked in polished bright anodised 2.1m lengths only

Stocked in polished bright anodised 3.0m lengths only

+ Only stocked in 6.0m lengths

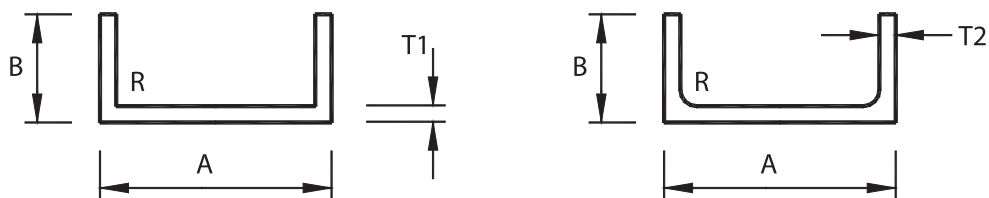

For NZ based customers. All lengths are stocked in 6060 T5 - mill finish - 5m lengths (unless specified)
All peripheries less than 100mm are deemed 100mm for surface finish purpose

Channels

SECTION NUMBER	A	B	T1	T2	R	MASS kg/m	OUTSIDE PERIM	STOCKED IN ANODISED
9677	40.00	20.00	1.60	1.60		0.332	156.80	
5982	40.00	20.00	3.00	3.00		0.599	154.00	
6452	40.00	25.00	3.00	3.00		0.680	174.00	
36089	43.80	43.80	3.00	3.00	2.00	1.010	252.82	
2114	44.50	25.00	3.00	3.00		0.717	183.00	
30735	46.50	40.00	3.00	3.00		0.980	247.00	
8521	50.00	16.00	3.00	3.00		0.616	158.00	
5983	50.00	25.00	3.00	3.00		0.761	194.00	
5984	50.00	50.00	3.00	3.00		1.166	294.00	
9056	53.20	25.00	1.20	1.20		0.324	203.00	
6330	54.00	20.00	1.50	1.50		0.370	185.00	
G743	60.00	12.00	3.00	3.00		0.634	161.48	
30487	75.00	25.00	3.00	3.00		0.967	244.00	
J458	80.00	40.00	3.00	3.00		1.252	314.00	
5854	92.50	25.50	3.00	1.60		0.942	278.00	
8716	100.00	25.00	3.00	3.00		1.166	294.00	
J089	100.00	50.00	3.00	3.00		1.577	394.00	
6982	100.00	50.00	6.00	6.00	0.80	3.046	387.00	
7059	125.00	60.00	6.00	6.00	6.00	3.816	454.00	
4760	150.00	75.00	5.00	5.00		3.915	590.00	

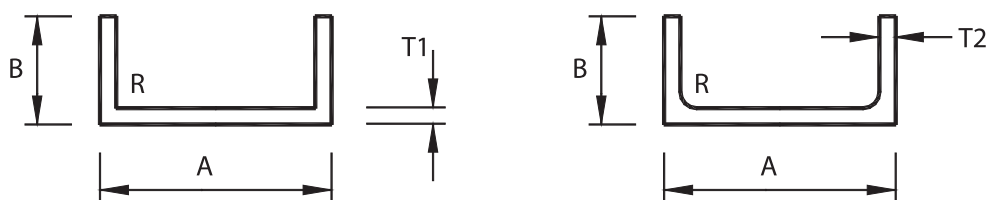

For NZ based customers. All lengths are stocked in 6060 T5 - mill finish - 5m lengths (unless specified)
 All peripheries less than 100mm are deemed 100mm for surface finish purpose

Flats

SECTION NUMBER	A	B	R	MASS kg/m	OUTSIDE PERIM	STOCKED IN ANODISED
J781	10.00	3.00		0.082	26.00	
J791 ⁺	12.00	3.00		0.097	30.00	
9741	12.00	6.00		0.194	36.00	
5991	16.00	3.00		0.130	38.00	✓
0632	19.05	4.00	2.00	0.195	42.60	
5989	20.00	1.60		0.087	43.20	
5992	20.00	3.00		0.162	46.00	✓
4954	20.00	6.00		0.325	52.00	
9336	25.00	1.60		0.108	53.20	✓
5993	25.00	3.00		0.203	56.00	
5996	25.00	6.00		0.405	62.00	
33943~	25.00	10.00	5.00	0.619	100.00	✓
5999	25.00	12.00		0.810	74.00	
0340	25.40	4.75		0.326	60.30	
0537	25.40	9.53		0.654	69.90	
34559	30.00	3.00		0.244	66.00	
0322	31.75	4.75		0.407	73.00	
0634	31.75	12.70		1.089	88.90	
4996	38.00	6.00		0.601	88.20	
0630	38.10	4.78		0.494	85.80	
6077	40.00	3.00		0.324	86.00	✓
6706	40.00	6.00		0.648	92.00	
7426	40.00	10.00		1.080	100.00	
1864	44.45	3.18		0.384	95.25	
K024	47.65	1.42		0.184	98.10	

+ Available in 6.0m lengths only

~ Available in anodised only

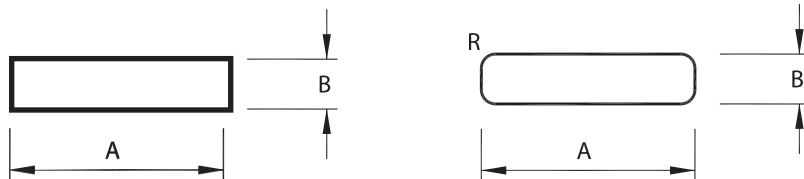

For NZ based customers. All lengths are stocked in 6060 T5 - mill finish - 5m lengths (unless specified)
All peripheries less than 100mm are deemed 100mm for surface finish purpose

Flats

SECTION NUMBER	A	B	R	MASS kg/m	OUTSIDE PERIM	STOCKED IN ANODISED
5994	50.00	3.00		0.405	106.00	✓
5997	50.00	6.00		0.810	112.00	
7425	50.00	10.00		1.350	120.00	
4978 [#]	50.00	25.00		3.382	147.25	
J403	60.00	3.00		0.488	126.00	
8776	60.00	6.00		0.972	132.00	
9777	60.00	12.00		1.944	143.70	
J900 [#]	64.00	32.10		5.567	192.20	
X190	75.00	5.00		1.014	158.23	
4989	76.20	3.00		0.620	158.40	✓
0529	76.20	9.53		1.961	171.50	
J723	80.00	1.60		0.347	163.20	
6373	80.00	3.00		0.648	166.00	
7040	80.00	6.00		1.296	172.00	
J712	100.00	1.60		0.433	203.20	
5995	100.00	3.00		0.810	206.00	✓
Z120	100.00	5.00		1.355	210.00	
5998	100.00	6.00		1.620	212.00	
8333	100.00	10.00		2.700	220.00	
E301	125.00	6.00		2.033	262.00	
3301	127.00	12.70		4.355	279.40	
33972	150.00	5.00		2.033	310.00	
5784	152.40	25.40		10.452	355.60	
E320	200.00	10.00		5.420	420.00	

Available in 6061 T6 only

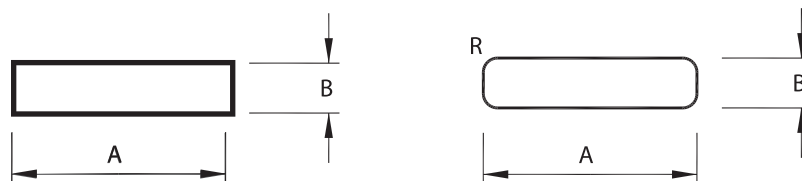

For NZ based customers. All lengths are stocked in 6060 T5 - mill finish - 5m lengths (unless specified)
All peripheries less than 100mm are deemed 100mm for surface finish purpose

Hollows - Square

SECTION NUMBER	A	T	R1	R2	MASS kg/m	OUTSIDE PERIM	STOCKED IN ANODISED
9609	12.70	1.60			0.189	50.80	
30211~	16.00	1.20	1.60		0.187	61.25	
5728	19.00	1.60	2.40	0.80	0.301	76.00	
8950	20.00	1.50			0.300	80.00	
8777	20.00	3.00	3.00		0.530	74.85	
9675*	25.00	1.40	2.40	1.00	0.346	95.90	
6614	25.00	1.60			0.404	100.00	
N285	25.00	1.80	3.00		0.432	94.85	
9784	25.00	3.00			0.713	99.70	
8778+	25.00	3.00	3.00		0.695	94.85	
7841+	30.00	2.00	2.50	1.50	0.596	115.70	
6947	30.00	3.00			0.875	120.00	
K362	32.00	2.00			0.650	128.00	
J169	32.00	3.00			0.943	128.00	
G677+	33.90	1.45	2.50		0.498	131.31	
K911	40.00	1.60			0.666	160.00	
9193	40.00	1.60	3.00	1.40	0.647	154.85	
G097	40.00	2.00			0.824	160.00	
30196^	40.00	2.00	2.40		0.811	155.88	
X592**	40.00	3.00			1.203	160.00	
N737+	40.00	3.00	3.00	1.00	1.185	154.85	
32003	40.00	5.00	2.50		1.883	155.71	
1468	44.45	2.03			0.933	177.80	
J309	50.00	1.60			0.840	200.00	
K132	50.00	1.60	6.00	4.00	0.801	189.90	
33479+	50.00	2.00	3.00	1.00	1.022	194.85	
31350+	50.00	2.00	6.40	4.40	0.990	189.01	
9746	50.00	2.50			1.283	200.00	
5917+	50.00	3.00			1.523	200.00	
32565+	50.00	3.00	3.00		1.510	194.85	
32734^*	50.00	5.00	4.00	2.00	2.411	193.13	
X549	50.80	3.18	3.00		1.621	198.05	
Z912	60.00	1.40	1.00	0.30	0.887	238.28	
K308	65.00	2.50			1.694	260.00	
K323	75.00	3.00			2.341	300.00	
33133"	75.00	4.00	6.00		3.004	289.70	
33397~	76.20	3.00	6.00	3.00	2.318	294.50	
X550~	76.20	6.35	15.90	9.60	4.434	277.50	
Z320#	100.00	3.00			3.154	400.00	
36058	100.00	5.00	3.00	0.50	5.129	394.85	
17231^-	150.00	2.90	2.00		4.615	596.57	

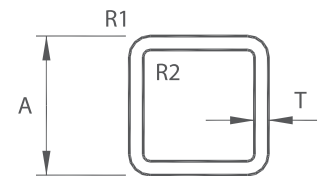
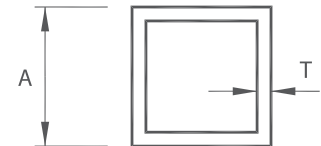

+ Also available in 6.0m lengths

* Also available in 6060 T4

** Also available in 6061 T5 in 6m lengths

Also available in 4.0m and 6.0m lengths

^ Also available in 6.0m and 6.5m lengths

~ Available in 6.0m lengths only

" Available in 6061 T6 in 5.0m lengths only

- Available in 2.8m, 3.7m & 6.5m lengths only

^* Also available in 6005 T6

For NZ based customers. All lengths are stocked in 6060 T5 - mill finish - 5m lengths (unless specified)
All peripheries less than 100mm are deemed 100mm for surface finish purpose

Hollows - Rectangular

SECTION NUMBER	A	B	T	R1	R2	MASS kg/m	OUTSIDE PERIM	STOCKED IN ANODISED
K496	37.40	14.40	1.20	3.00	2.00	0.308	98.20	
9406	38.00	25.00	1.50	3.00	1.50	0.470	120.80	
X510 ⁺	38.00	25.00	2.00	3.00	1.50	0.622	120.85	
30486 ⁺	40.00	20.00	1.60			0.493	120.00	
30485	40.00	20.00	3.00			0.878	120.00	
K582	40.00	25.00	2.00			0.661	130.00	
35493 [#]	40.00	25.00	2.00	3.00	1.50	0.646	124.85	
E905	50.00	25.00	1.60			0.623	150.00	
34406 [~]	50.00	25.00	2.00	3.00	1.50	0.751	144.85	
9433	50.00	25.00	3.00			1.118	150.00	
X544 ⁺	50.00	25.00	3.00	3.00		1.101	144.85	
37044	50.00	30.00	2.00			0.824	160.00	
30497	50.00	40.00	2.00			0.932	180.00	
G705	50.00	40.00	3.00			1.366	180.00	
0914	50.80	38.10	3.18			1.417	177.80	
Z913	60.00	30.00	1.40	1.00	0.30	0.659	178.28	
J090	60.00	40.00	3.00			1.528	200.00	
Z357	65.00	16.00	1.20	3.00	2.00	0.500	156.85	
7652	70.00	40.00	3.00			1.691	220.00	
31442	75.00	25.00	3.00	1.00		1.526	198.28	
30837	75.00	40.00	2.00			1.203	229.31	
E709	75.00	50.00	2.50			1.626	250.00	
K011	76.00	25.00	2.40			1.252	202.00	
K910	80.00	40.00	3.00			1.854	240.00	
6490	80.00	50.00	3.00			2.008	260.00	
30240 ⁺	80.00	50.00	3.00	5.00	2.00	1.967	251.42	
31300 [^]	100.00	25.00	1.60			1.056	250.00	
6669 [~]	100.00	25.00	2.50			1.626	250.00	
7955	100.00	45.00	3.00			2.252	290.00	
J845	100.00	50.00	2.00			1.583	300.00	
9985 ⁺	100.00	50.00	3.00			2.341	300.00	
30752 [~]	100.00	50.00	3.00	4.00	1.00	2.307	293.13	
34048	100.00	50.00	4.00			3.079	300.00	
K102 [~]	100.00	50.00	6.00	8.00	2.00	4.348	286.27	
G589	125.00	40.00	3.00			2.585	330.00	
J863 ⁺	150.00	50.00	3.00			3.154	400.00	
30388	150.00	75.00	5.00	5.00	2.50	5.783	441.42	
Z335 ⁻	200.00	50.00	3.00			3.960	500.00	✓
35513 [*]	250.00	50.00	3.00	0.40		4.780	599.31	

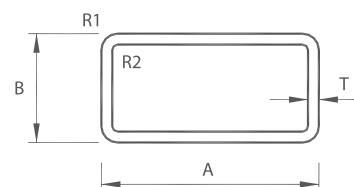
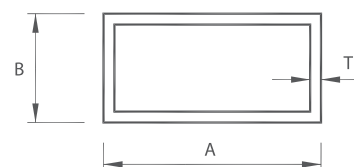

- + Also available in 6.0m lengths
- Also available in 4.0m, 6.0m and 6.5m lengths
- * Also available in 4.0m and 6.5m lengths
- ~ Available in 6.0m lengths only
- # Available in 6.75m lengths only
- ^ Available in 5.1m and 6.0m lengths

For NZ based customers. All lengths are stocked in 6060 T5 - mill finish - 5m lengths (unless specified)
All peripheries less than 100mm are deemed 100mm for surface finish purpose

Solid Rods

SECTION NUMBER	O.D.	MASS kg/m	OUTSIDE PERIM
RD0063	6.35	0.086	19.95
RD0095	9.53	0.193	29.94
RD0120~	12.00	0.306	37.70
RD0127	12.70	0.342	39.90
RD0159	15.88	0.537	49.89
RD0160	16.00	0.545	50.30
RD0190	19.05	0.769	59.85
RD0200*	20.00	0.851	62.80
RD0222	22.23	1.052	69.84
RD0254	25.40	1.375	79.80
RD0270	27.00	1.555	84.80
RD0317	31.75	2.138	99.75
RD0349	34.90	2.587	109.74
RD0381	38.10	3.078	119.69
RD0445	44.50	4.190	139.64
RD0500	50.00	5.321	157.08
RD0508	50.80	5.472	159.59
RD0520^	52.00	5.755	163.36
RD0540	54.00	6.206	169.65
RD0571	57.15	6.926	179.54
RD0603	60.32	7.715	189.50
RD0699	69.90	10.361	219.59
RD0762	76.20	12.313	239.40
RD0889	88.90	16.760	279.29
RD1016#	101.60	21.890	319.19
RD1270+	127.00	34.320	398.98

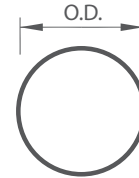

~ Available in 5.0m lengths only

* Also available in 6060 T5

+ Available in 600mm lengths only

Available in 2.5m lengths only

^ Stocked in Christchurch warehouse only

Sold in 3.6m lengths, 6061 T6 alloy / temper unless indicated.

For NZ based customers. All lengths are stocked in 6060 T5 - mill finish - 5m lengths (unless specified)
All peripheries less than 100mm are deemed 100mm for surface finish purpose

Extruded Tubes

SECTION NUMBER	O.D.	W.T.	MASS kg/m	OUTSIDE PERIM	STOCKED IN ANODISED
TU8090	9.53	1.42	0.098	29.90	
TU8110	12.70	1.42	0.136	39.90	
TU8020#	15.88	1.22	0.152	49.90	
TU8120	15.88	1.42	0.174	49.90	
TU8260~	15.88	1.63	0.197	49.90	
TU8530	15.88	2.64	0.297	49.90	
TU8014	16.00	1.20	0.151	50.30	
TU8030	19.05	1.22	0.185	59.80	
TU8140	19.05	1.42	0.213	59.80	
TU8240	20.00	1.60	0.251	62.80	BRIGHT ANODISED
TU8035	22.23	1.22	0.217	69.80	
TU8290	22.23	1.63	0.284	39.80	
TU8218	25.00	1.50	0.300	78.50	
TU8440	25.00	2.00	0.390	78.50	
TU8575!	25.00	3.00	0.562	78.50	BRIGHT ANODISED
TU8160	25.40	1.42	0.290	79.80	
TU8580	25.40	3.00	0.573	79.80	
TU8170	28.58	1.42	0.327	89.80	✓
TU8180	31.75	1.42	0.366	99.70	
TU8601	32.00	3.00	0.741	100.50	
TU8190	38.10	1.42	0.443	119.70	
TU8523	38.10	2.40	0.724	119.70	
TU8610	38.10	3.00	0.896	119.70	
TU8441	40.00	2.00	0.647	125.70	
TU8615	40.00	3.00	0.942	125.70	
TU8524	43.30	2.50	0.868	136.03	
TU8442	44.45	2.00	0.723	139.60	
TU8620	44.45	3.00	1.059	139.60	
TU8555+	48.40	2.60	1.014	152.10	
TU8780+	48.41	4.47	1.666	152.10	
TU8443^	50.00	2.00	0.817	157.08	
TU8630	50.00	3.00	1.196	157.10	
TU8640	50.80	3.00	1.216	159.60	
TU8650	57.00	3.00	1.374	179.10	
TU8447	63.50	2.00	1.047	199.49	
TU8720	63.50	3.25	1.661	199.50	
TU8651	80.00	3.00	1.959	251.30	
TU8655	100.00	3.00	2.478	314.20	

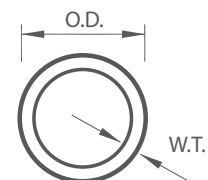

- + Available in 6005 T6 6.0m lengths (scaffolding tube)
- # Available in 6.0m lengths only
- ~ Available in 6063 T6 6.0m lengths only
- ^ Also available in 6063 T6 5.0m lengths and 6060 T5 6.0m lengths
- ! Stocked in 6.0m, 6060 T52 or polished bright anodised 5.0m only

For NZ based customers. All lengths are stocked in 6060 T5 - mill finish - 5m lengths (unless specified)
All peripheries less than 100mm are deemed 100mm for surface finish purpose

Tees, Solid Squares & Other

Tees

SECTION NUMBER	A	B	T	R	MASS kg/m	OUTSIDE PERIM	LENGTH
5985	20.00	20.00	1.60		0.166	80.00	5.00
4870	25.00	25.00	3.00		0.382	100.00	5.00
5988	40.00	40.00	3.00		0.624	160.00	5.00
37805	75.00	125.00	10.00		5.147	397.94	5.00
31117	50.00	100.00	6.00	4.00	2.357	293.99	5.00
1184	50.80	50.80	4.75	6.10	1.284	198.00	5.00
1478	63.50	63.50	6.35	6.86	2.123	248.10	5.00

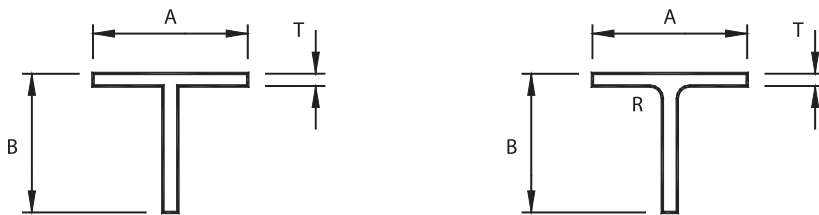

Solid Squares

SECTION NUMBER	O.D.	MASS kg/m	OUTSIDE PERIM	LENGTH
SQ0064	6.40	0.109	25.40	4.00
SQ0100	10.00	0.271	40.00	4.00
SQ0120	12.00	0.390	48.00	4.00
SQ0160	16.00	0.694	64.00	5.00
SQ0200	20.00	1.084	80.00	4.00
SQ0250	25.00	1.694	100.00	5.00
SQ0318*	31.75	2.721	127.00	3.60
SQ0381*	38.10	3.919	152.40	3.60
SQ0445*	44.50	5.335	177.80	3.60

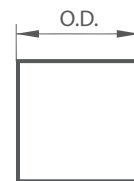

* Available in 6061 T6 only

Other

SECTION NUMBER	SHAPE	O.D.	MASS kg/m	OUTSIDE PERIM	LENGTH
HX0111*	Solid Hex	11.10	0.290	38.46	3.6

* Available in 6061 T6 only

SECTION NUMBER	SHAPE	A	B	T	MASS kg/m	OUTSIDE PERIM	LENGTH
8069	I-BEAM~	100.00	50.00		2.599	378.30	5.00
4519	TOP HAT	38.10	12.70	1.57	0.256	124.00	5.00
G902	I-BEAM	105.00	60.00	1.80	1.078	444.57	5.00

~ Please refer to McKechnie® Aluminium Mill Run Standards Catalogue for full dimensions

For NZ based customers. All lengths are stocked in 6060 T5 - mill finish - 5m lengths (unless specified)
All peripheries less than 100mm are deemed 100mm for surface finish purpose

Commercial Suites

McKechnie® Sections

Stocked Products

updated April 2024



Pacific Commercial Door

SECTION NUMBER	MASS kg/m	OUTSIDE PERIM	LENGTH	FINISH	
				MILL	NAT 12um
0732	1.154	181.00	5.00	✓	✓
0749	1.171	229.00	5.00	✓	
5584	0.987	340.00	5.00	✓	✓
5620	0.484	157.03	5.00	✓	CHCH ONLY
5622	1.299	214.50	5.00	✓	CHCH ONLY
5653	0.166	97.50	5.00	✓	✓
6100	1.961	313.49	5.00	✓	CHCH ONLY
6136 [#]	0.150	72.23	5.00	✓	✓
6350	0.518	127.00	5.00	✓	✓
8163	1.732	292.18	5.00	✓	
8164	2.232	409.78	5.00	✓	
8165	2.285	363.32	5.00	✓	
8166	1.325	260.46	5.00	✓	
8167	0.131	81.99	5.00	✓	
9987	1.617	268.10	5.00	✓	
G249	1.510	331.00	2.80	✓	✓
G249	1.510	331.00	3.60	✓	
G249	1.510	331.00	4.50	✓	✓
G250	1.470	285.12	2.80	✓	✓
G250	1.470	285.12	3.60	✓	
G250	1.470	285.12	4.50	✓	✓
G251	1.400	484.40	5.00	✓	
G419	1.914	436.36	2.80	✓	
G419	1.914	436.36	5.00	✓	
G611	1.998	421.05	2.80	✓	
G611	1.998	421.05	5.00	✓	✓
31882	2.072	384.15	5.00	CHCH ONLY	CHCH ONLY
33143	1.626	247.85	5.00	CHCH ONLY	CHCH ONLY
33445	0.373	177.47	5.00	✓	
32550	0.194	87.28	5.00	✓	
35647	0.250	118.13	5.00	✓	

Also available in 3.0m lengths

For NZ based customers. All lengths are stocked in 6060 T5 - mill finish - 5m lengths (unless specified)
All peripheries less than 100mm are deemed 100mm for surface finish purpose

Pacific Commercial Door

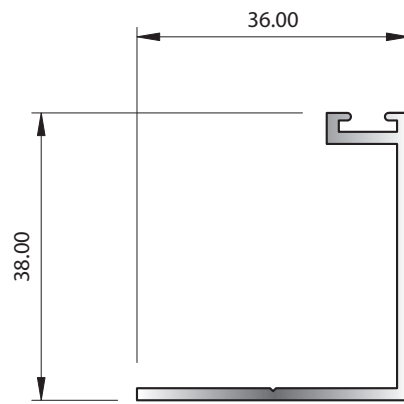
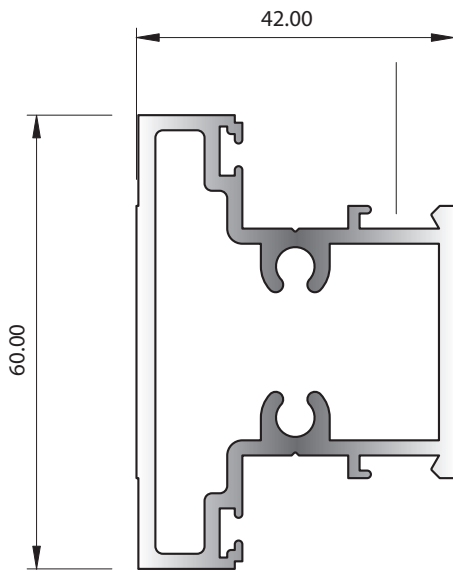
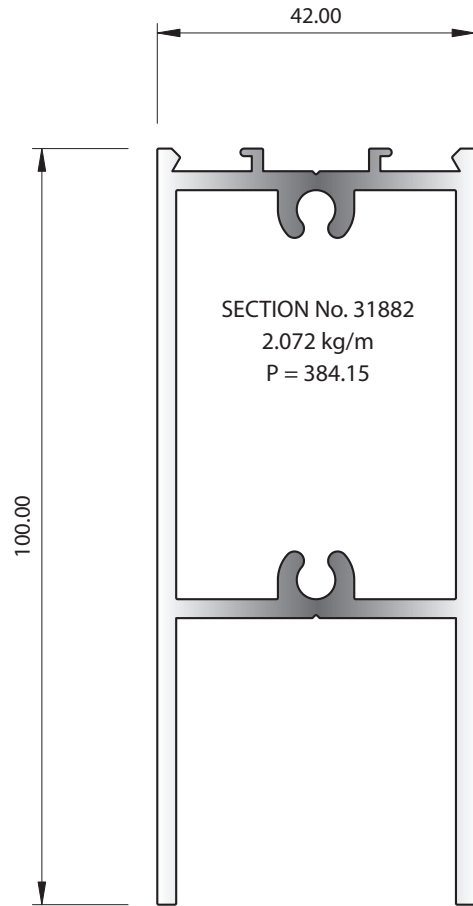
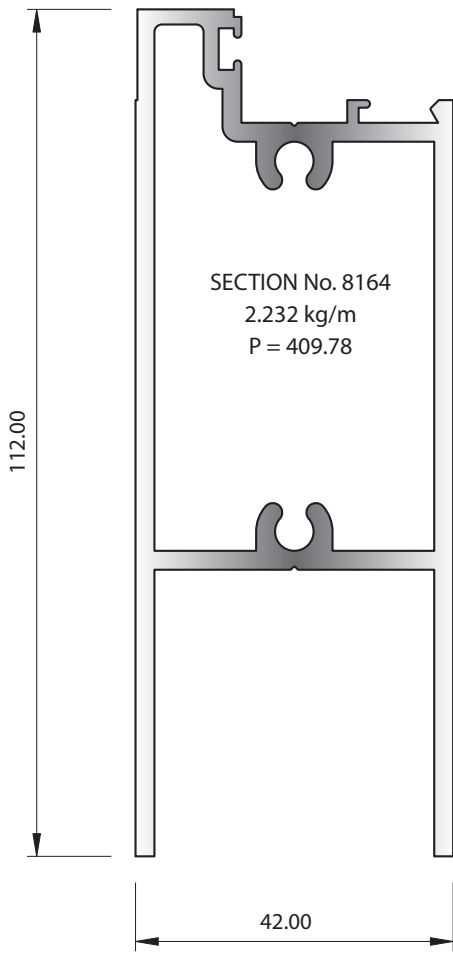

SECTION No. G251
1.400 kg/m
P = 484.40

SECTION No. 33445
0.373 kg/m
P = 177.47

For NZ based customers. All lengths are stocked in 6060 T5 - mill finish - 5m lengths (unless specified)
All peripheries less than 100mm are deemed 100mm for surface finish purpose

Pacific Commercial Door

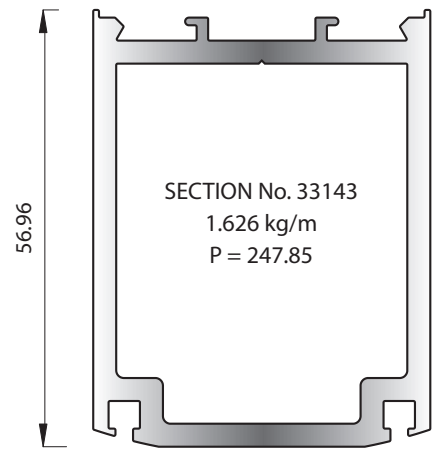
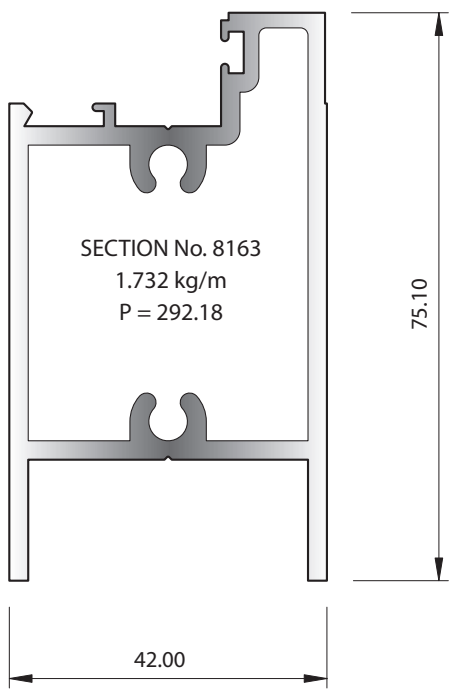
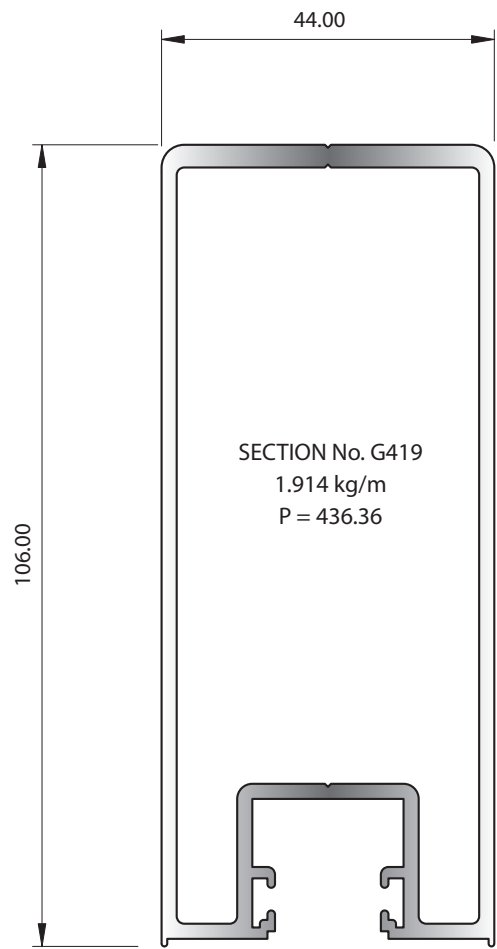
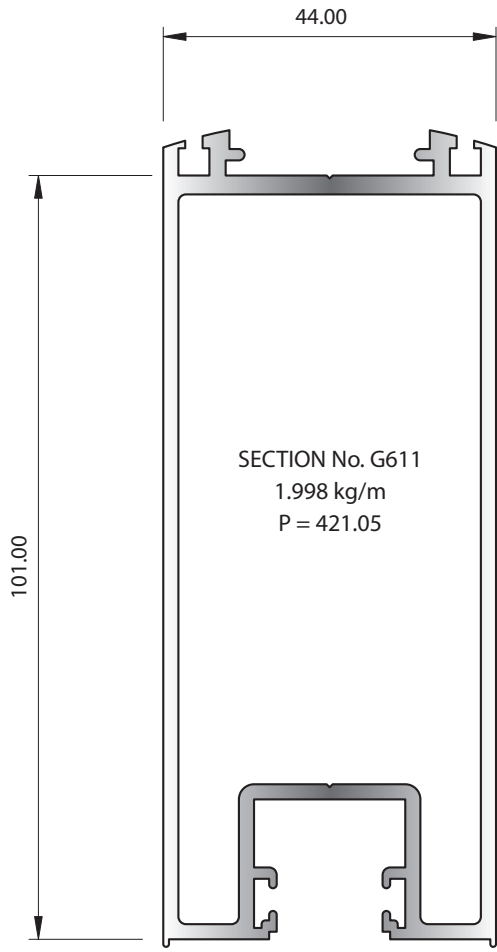

For NZ based customers. All lengths are stocked in 6060 T5 - mill finish - 5m lengths (unless specified)
All peripheries less than 100mm are deemed 100mm for surface finish purpose

Pacific Commercial Door

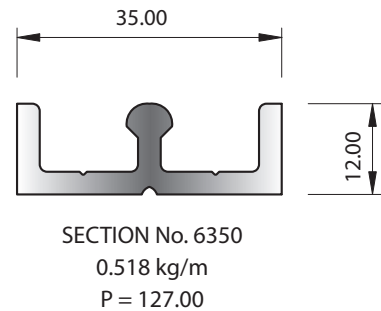
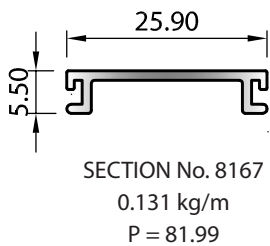
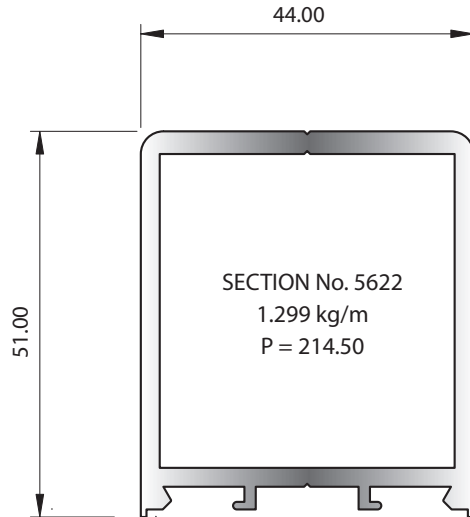
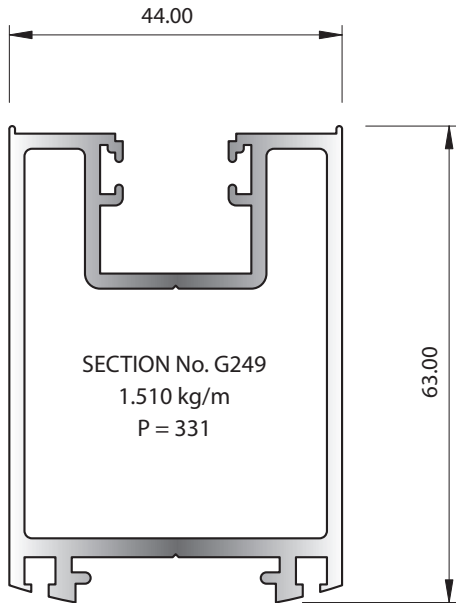
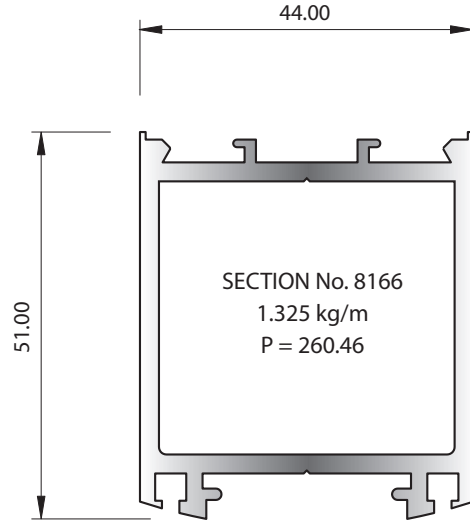
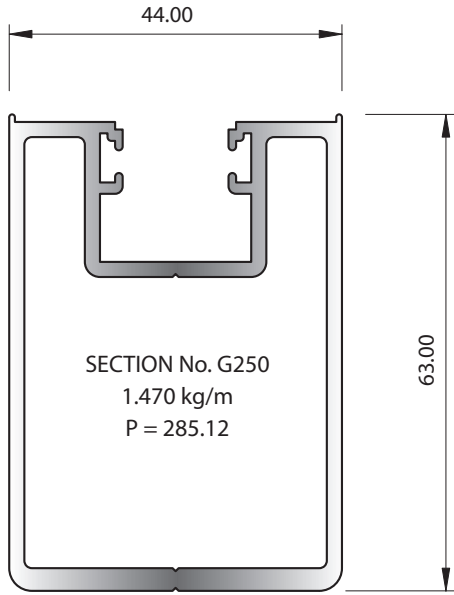

For NZ based customers. All lengths are stocked in 6060 T5 - mill finish - 5m lengths (unless specified)
All peripheries less than 100mm are deemed 100mm for surface finish purpose

Pacific Commercial Door

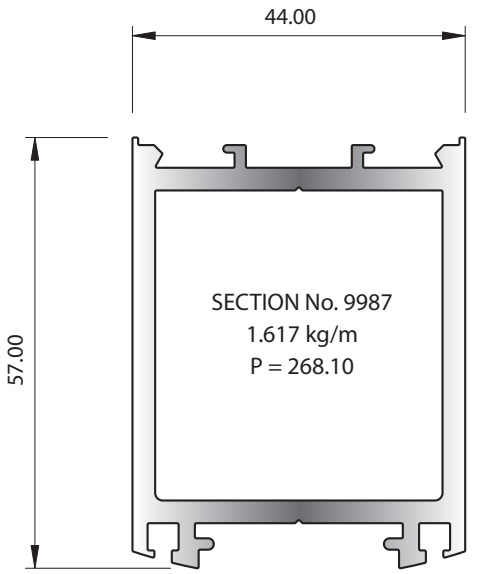
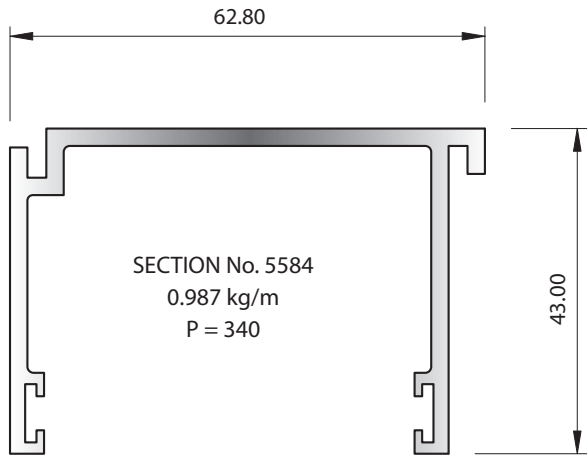
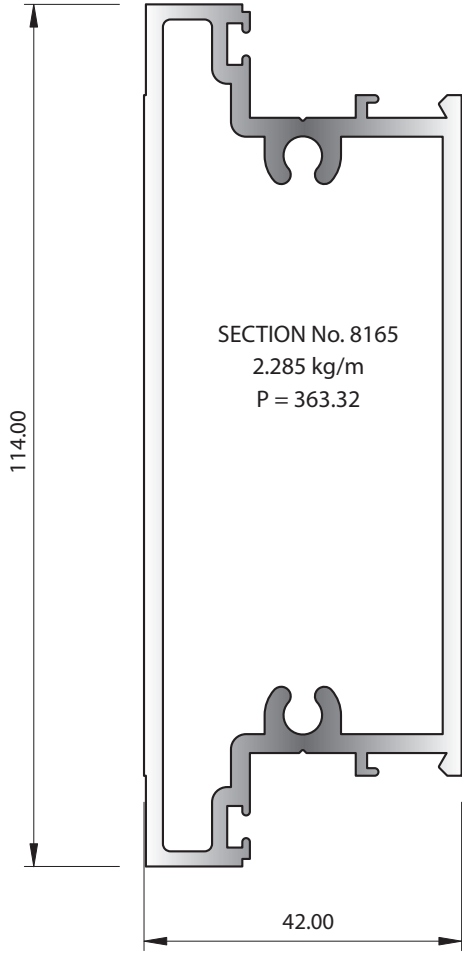
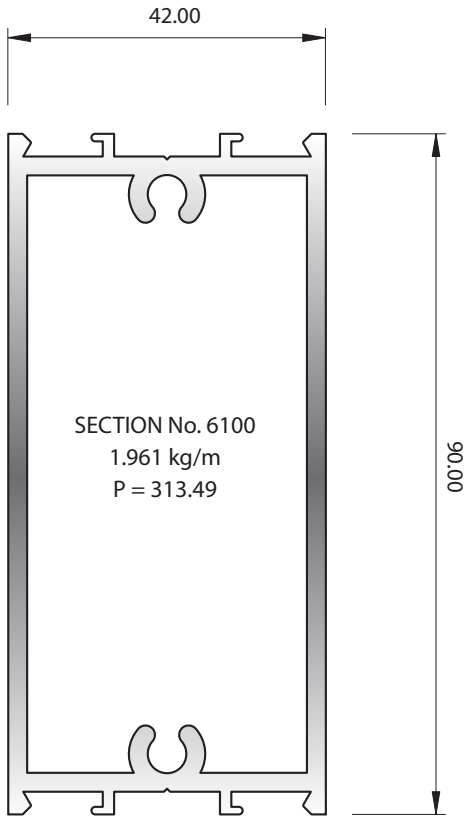

For NZ based customers. All lengths are stocked in 6060 T5 - mill finish - 5m lengths (unless specified)
All peripheries less than 100mm are deemed 100mm for surface finish purpose

Pacific Commercial Door

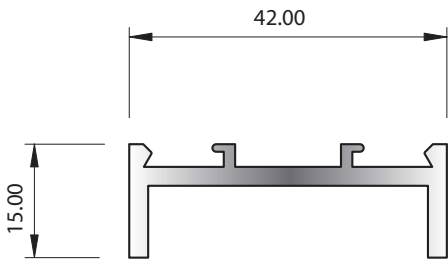

SECTION No. 5620
0.484 kg/m
P = 157.03

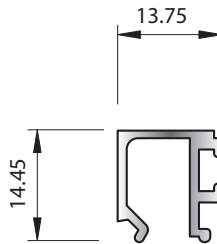

SECTION No. 5653
0.166 kg/m
P = 97.50

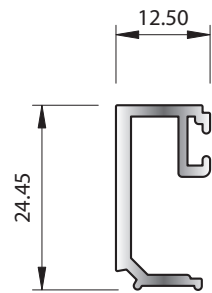

SECTION No. 35647
0.250 kg/m
P = 118.13

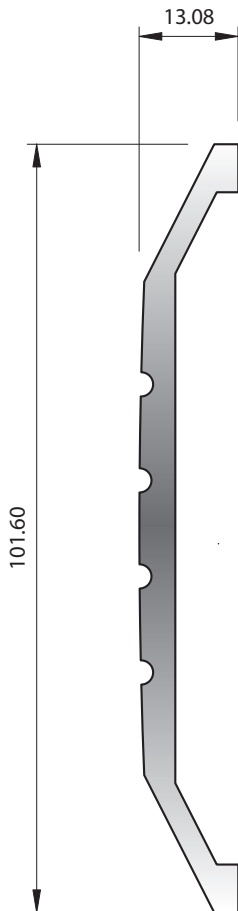

SECTION No. 0749
1.171 kg/m
P = 229

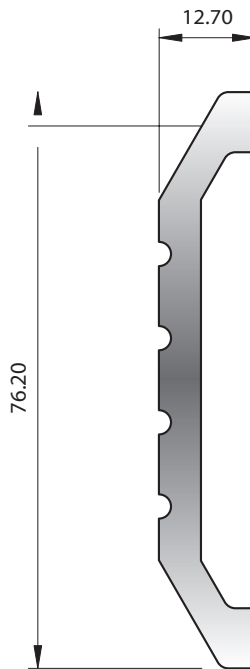

SECTION No. 0732
1.154 kg/m
P = 181

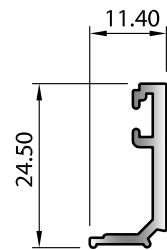

SECTION No. 32550
0.194 kg/m
P = 87.28

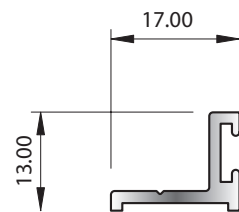

SECTION No. 6136
0.150 kg/m
P = 72.23

For NZ based customers. All lengths are stocked in 6060 T5 - mill finish - 5m lengths (unless specified)
All peripheries less than 100mm are deemed 100mm for surface finish purpose

Pacific Shopfront 75 Series

SECTION NUMBER	MASS kg/m	OUTSIDE PERIM	LENGTH	FINISH	
				MILL	NAT 12um
3882	1.569	563.80	5.00	✓	✓
4895	0.595	278.45	5.00	✓	
5581	0.429	181.58	5.00	✓	✓
5706	0.126	77.00	5.00	✓	
6726	1.066	387.00	5.00	✓	
7752	1.808	318.23	5.00	✓	
7754	0.267	149.88	5.00	✓	
7771	1.532	240.00	5.00	✓	
8136	0.281	157.00	5.00	✓	
30771	0.511	247.49	5.00	✓	✓
G058	1.057	511.10	5.00	✓	
G058	1.057	511.10	6.00	✓	
G059	1.398	505.10	5.00	✓	
G062	0.579	280.67	5.00	✓	✓
G062	0.579	280.67	6.00	✓	✓
G083	0.927	422.42	5.00	✓	

For NZ based customers. All lengths are stocked in 6060 T5 - mill finish - 5m lengths (unless specified)
All peripheries less than 100mm are deemed 100mm for surface finish purpose

Pacific Shopfront 75 Series

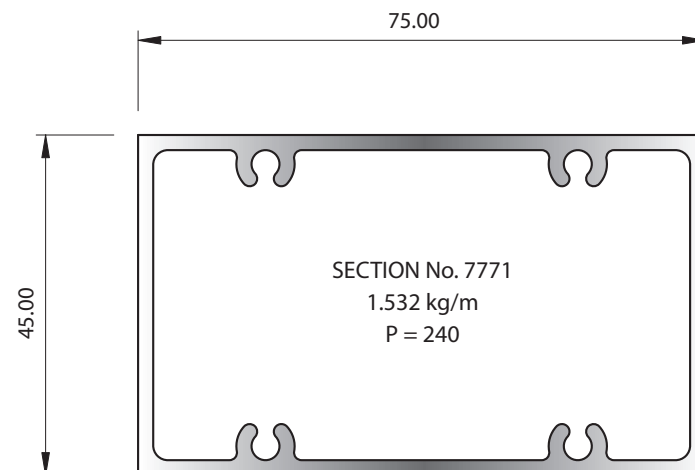
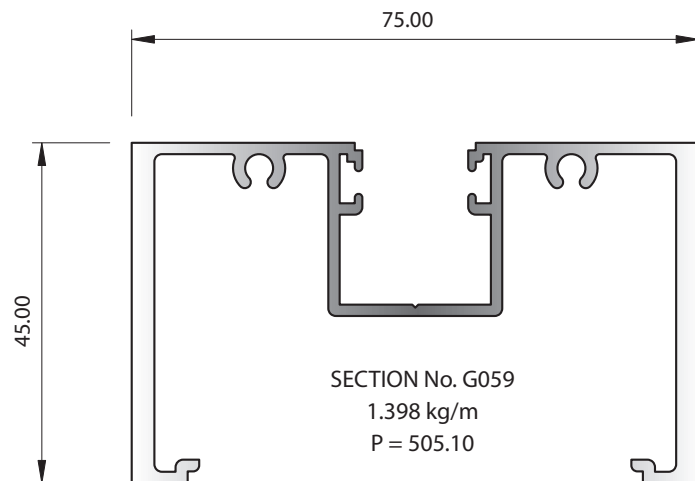
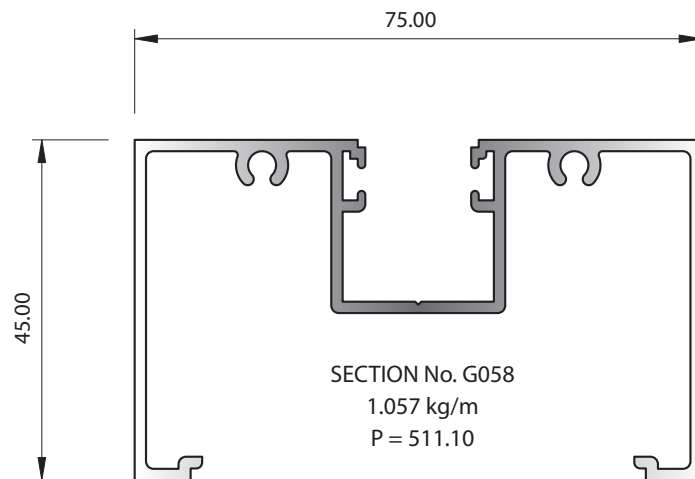

For NZ based customers. All lengths are stocked in 6060 T5 - mill finish - 5m lengths (unless specified)
All peripheries less than 100mm are deemed 100mm for surface finish purpose

Pacific Shopfront 75 Series

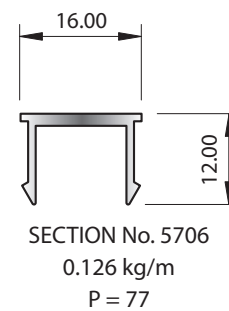
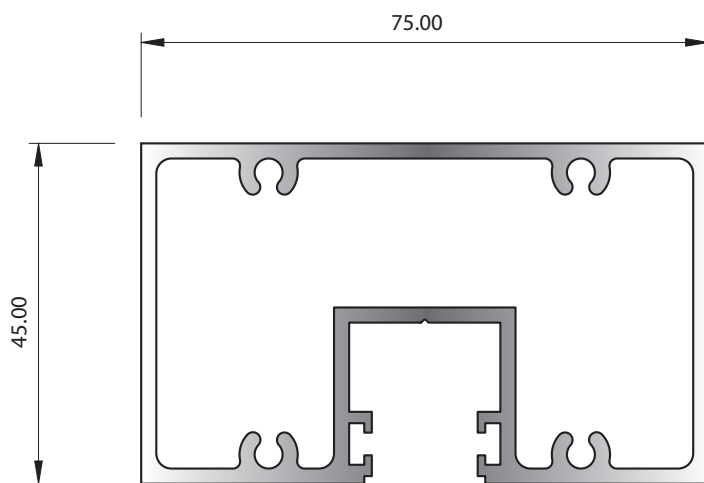
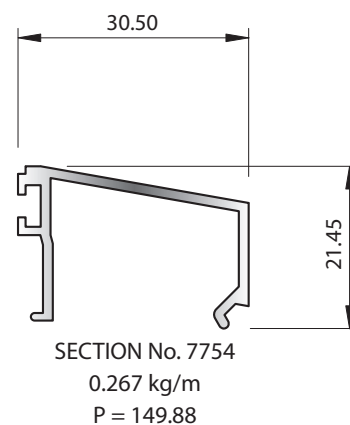
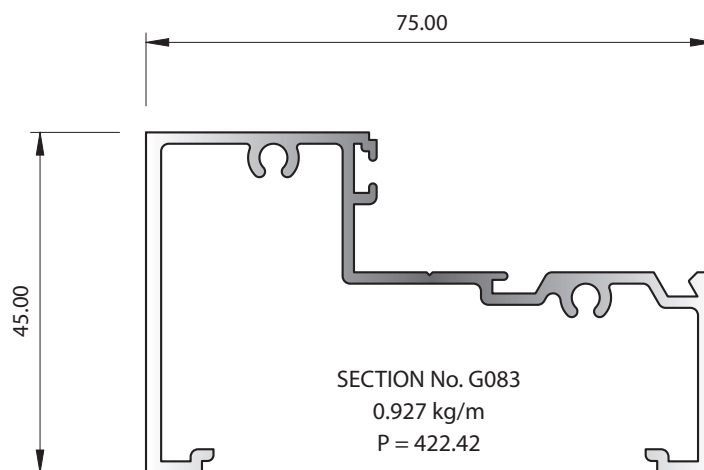
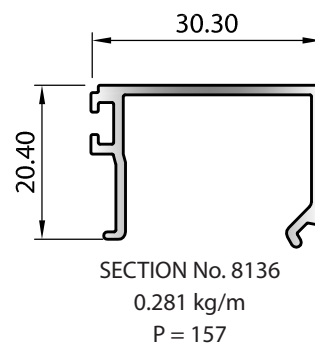
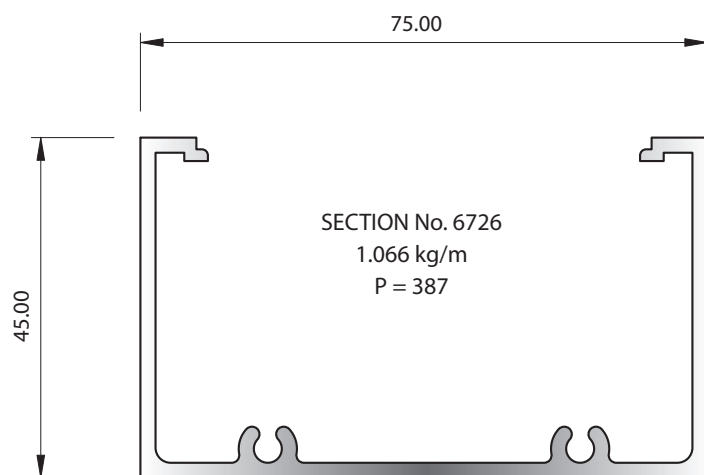

For NZ based customers. All lengths are stocked in 6060 T5 - mill finish - 5m lengths (unless specified)
All peripheries less than 100mm are deemed 100mm for surface finish purpose

Pacific Shopfront 75 Series

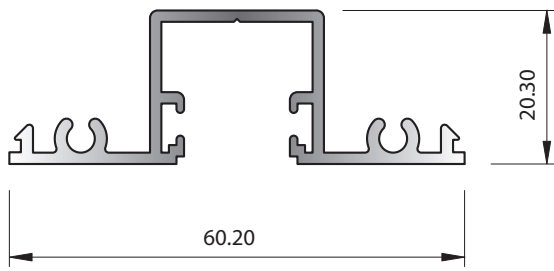

SECTION No. G062
0.579 kg/m
P = 280.67
75/100 SERIES

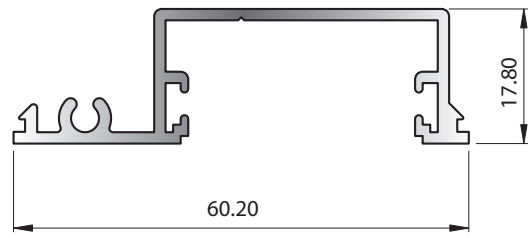

SECTION No. 30771
0.511 kg/m
P = 247.49

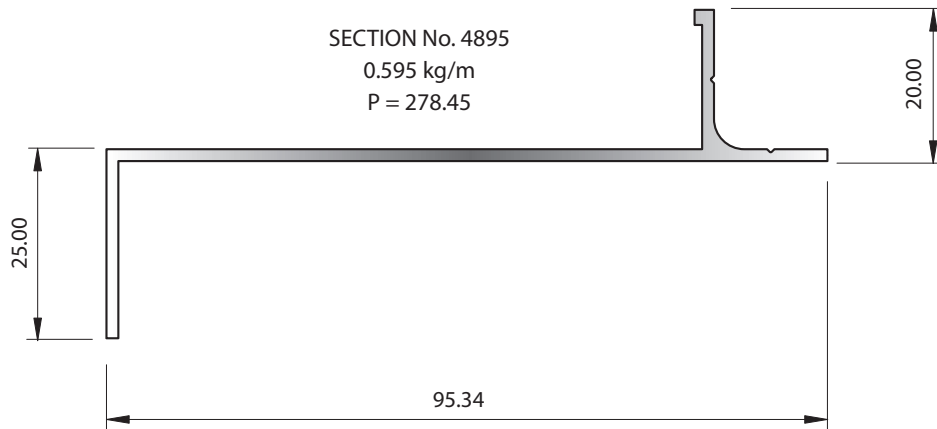

SECTION No. 4895
0.595 kg/m
P = 278.45

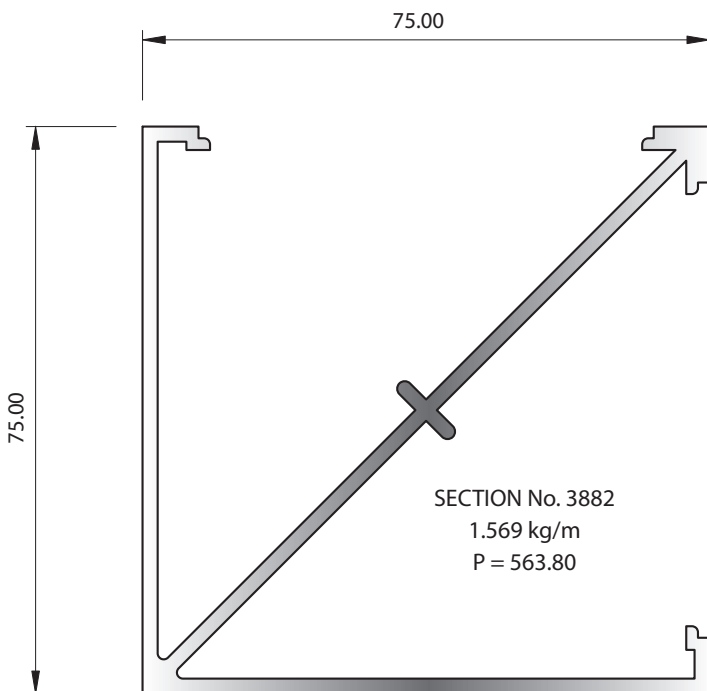

SECTION No. 3882
1.569 kg/m
P = 563.80

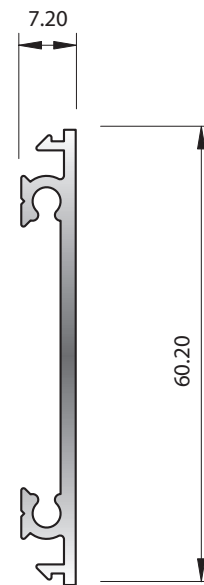

SECTION No. 5581
0.429 kg/m
P = 181.58

For NZ based customers. All lengths are stocked in 6060 T5 - mill finish - 5m lengths (unless specified)
All peripheries less than 100mm are deemed 100mm for surface finish purpose

Pacific Shopfront 100 Series

SECTION NUMBER	MASS kg/m	OUTSIDE PERIM	LENGTH	FINISH	
				MILL	NAT 12µm
4969	0.703	329.25	5.00	✓	
5581	0.429	181.58	5.00	✓	✓
5706	0.126	77.00	5.00	✓	✓
7757	0.384	199.13	5.00	✓	
9698	0.650	254.00	5.00	✓	
9699	2.914	311.40	5.00	✓	
9944	2.596	749.11	6.00	✓	CHCH ONLY
30299	0.399	212.14	5.00	CHCH ONLY	CHCH ONLY
30771	0.511	247.49	5.00	CHCH ONLY	CHCH ONLY
30772	0.380	202.94	5.00	CHCH ONLY	
G060	1.295	513.70	5.00	✓	✓
G061	1.531	604.65	5.00	✓	✓
G061	1.531	604.65	6.00	✓	CHCH ONLY
G062	0.579	280.67	5.00	✓	✓
G062	0.579	280.67	6.00	✓	✓
G252	2.828	576.60	5.00	✓	
N452	1.519	505.40	5.00	✓	
6558	0.977	315.51	5.00	✓	

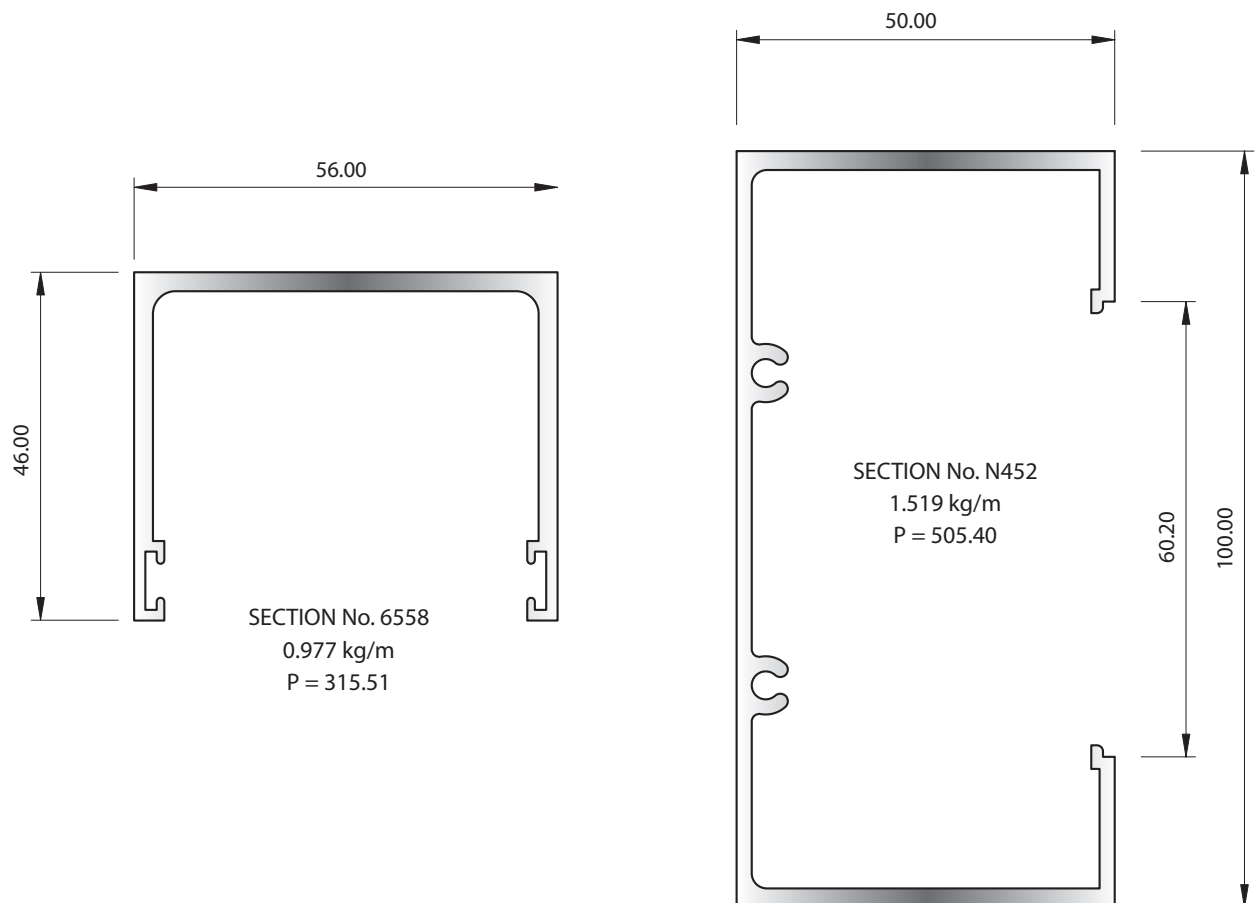

For NZ based customers. All lengths are stocked in 6060 T5 - mill finish - 5m lengths (unless specified)
All peripheries less than 100mm are deemed 100mm for surface finish purpose

Pacific Shopfront 100 Series

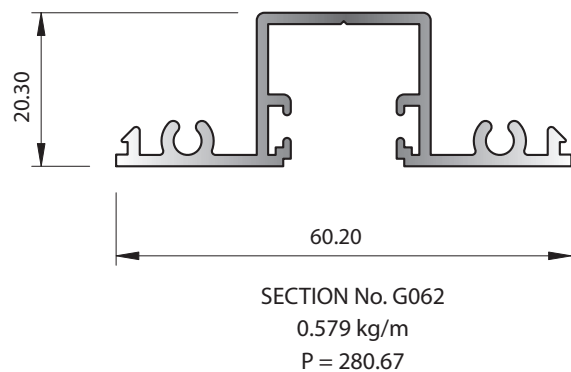
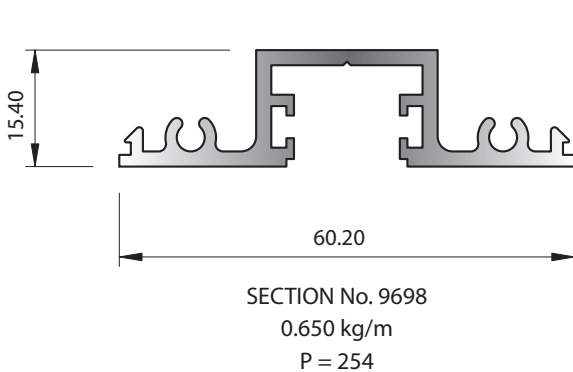
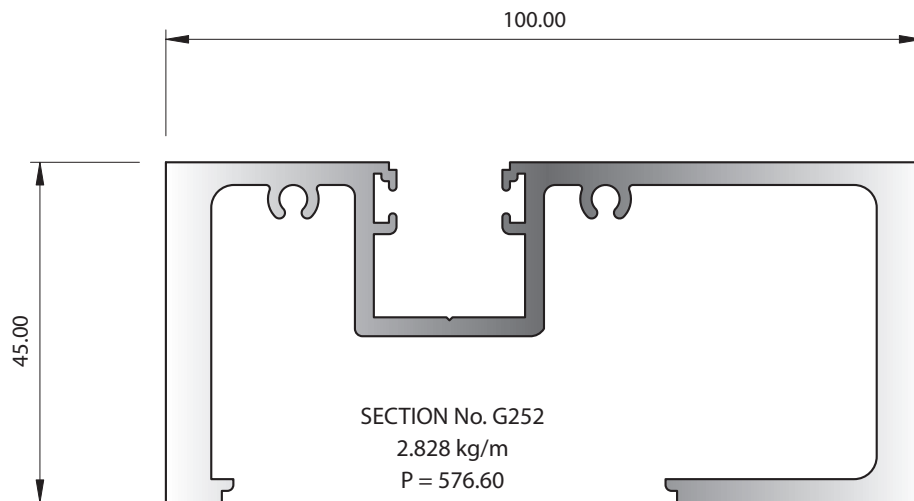
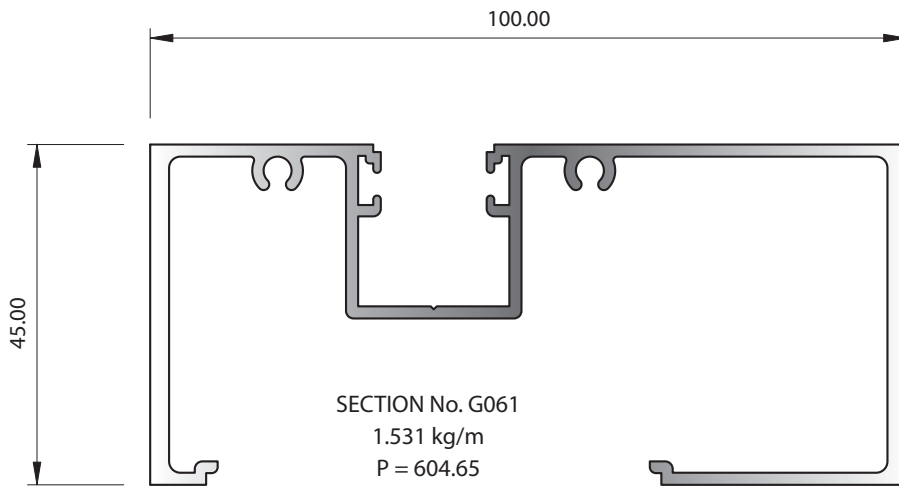

For NZ based customers. All lengths are stocked in 6060 T5 - mill finish - 5m lengths (unless specified)
All peripheries less than 100mm are deemed 100mm for surface finish purpose

Pacific Shopfront 100 Series

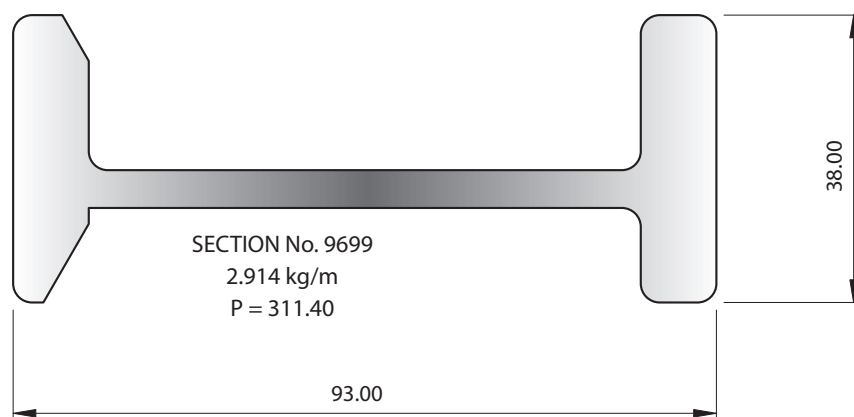
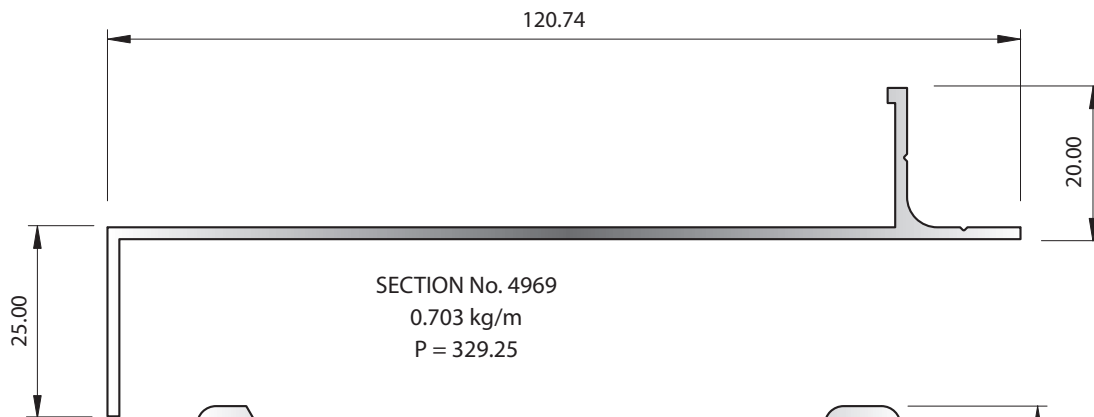
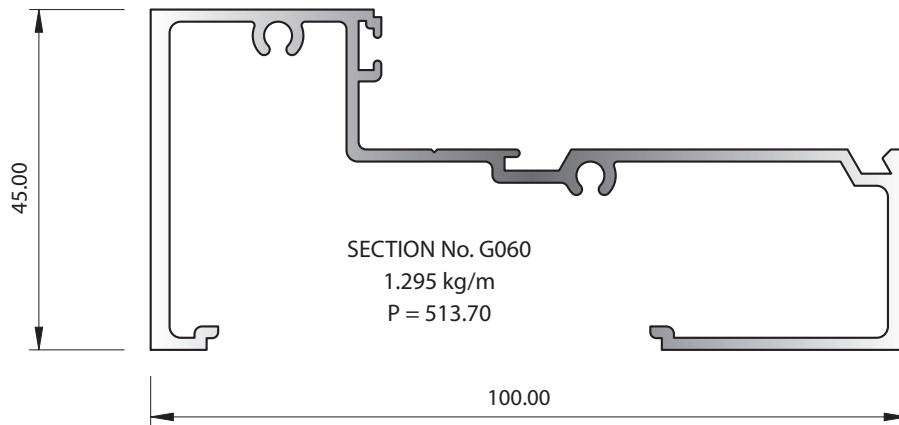
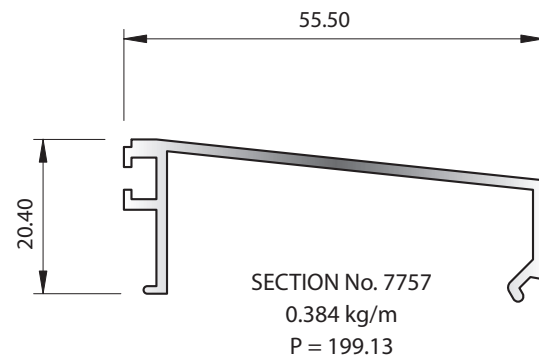
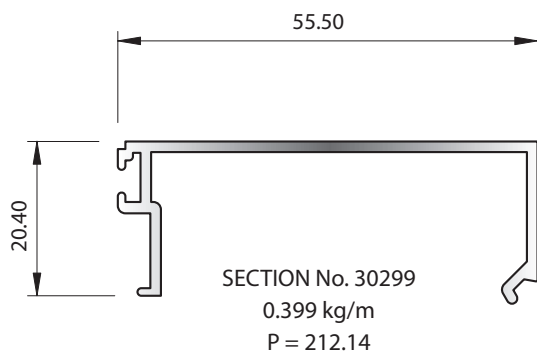

For NZ based customers. All lengths are stocked in 6060 T5 - mill finish - 5m lengths (unless specified)
All peripheries less than 100mm are deemed 100mm for surface finish purpose

Pacific Shopfront 100 Series

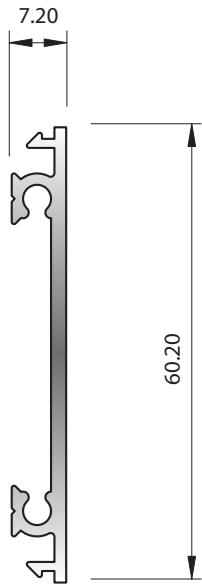

SECTION No. 5581
0.429 kg/m
P = 181.58

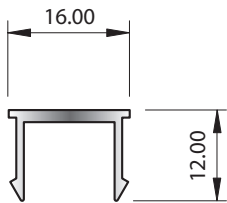

SECTION No. 5706
0.126 kg/m
P = 77.00

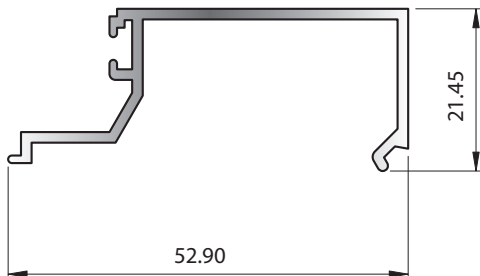
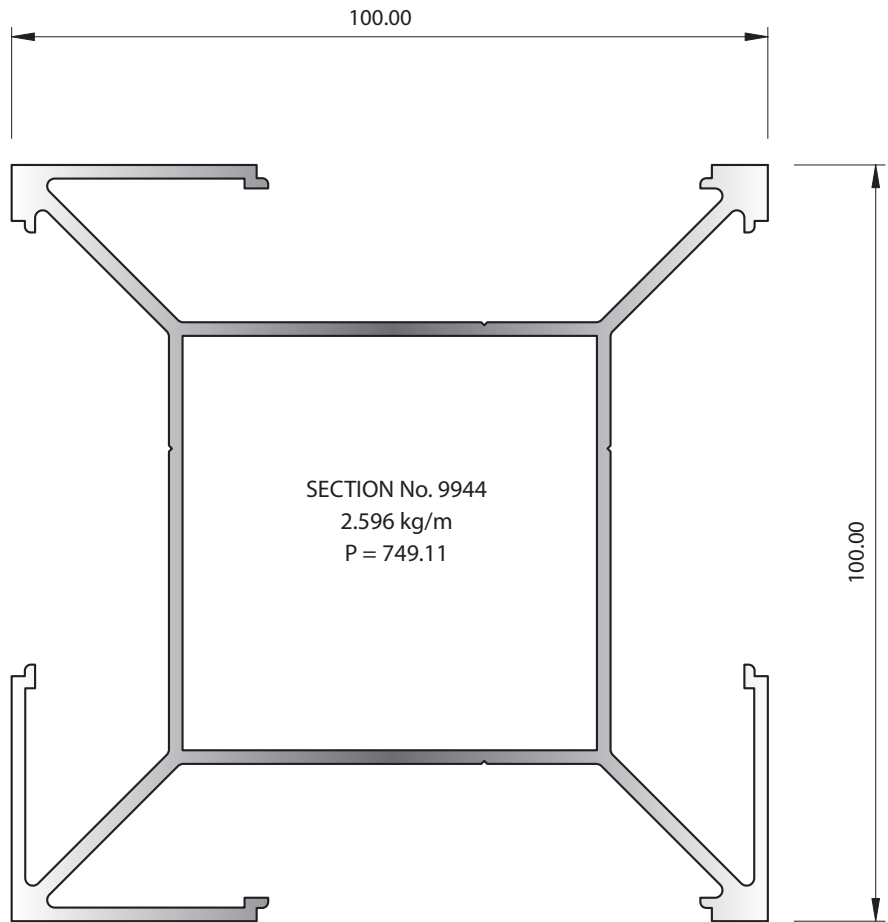

SECTION No. 30772
0.380 kg/m
P = 202.94

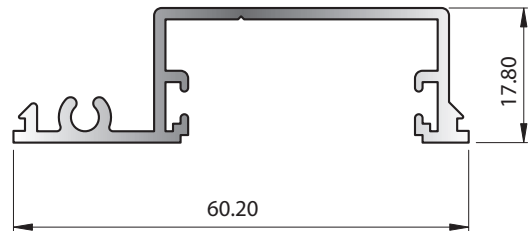

SECTION No. 30771
0.511 kg/m
P = 247.49

For NZ based customers. All lengths are stocked in 6060 T5 - mill finish - 5m lengths (unless specified)
All peripheries less than 100mm are deemed 100mm for surface finish purpose

Coolstore

SECTION NUMBER	MASS kg/m	OUTSIDE PERIM	LENGTH
9056	0.324	203.00	5.00
6330	0.370	185.00	5.00
7414	0.620	200.87	5.00
7789	0.360	118.32	5.00
8570	0.501	226.56	5.00
31346	0.714	355.15	5.00
31347	0.614	304.48	5.00
31348	0.511	255.15	5.00
31465	0.325	160.14	5.00
K574	0.287	157.90	5.00
Z381	0.769	279.34	5.00
Z382	1.326	428.12	5.00
Z383*	0.953	328.12	5.00
G902	1.078	444.57	5.00
8174	0.831	260.61	5.00

* Stocked in Christchurch warehouse only

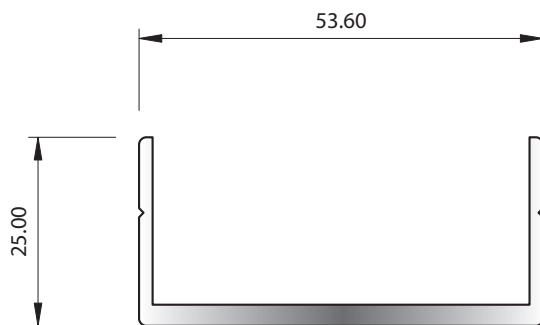

SECTION No. 7414
0.620 kg/m
P = 200.87

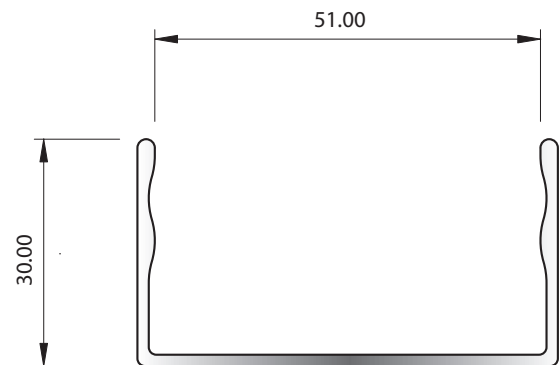

SECTION No. 8570
0.501 kg/m
P = 226.56

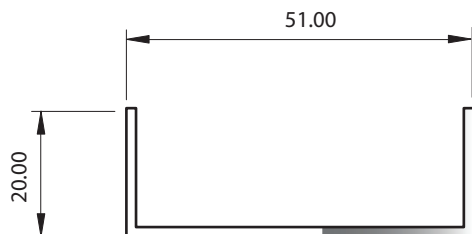

SECTION No. 6330
0.370 kg/m
P = 185

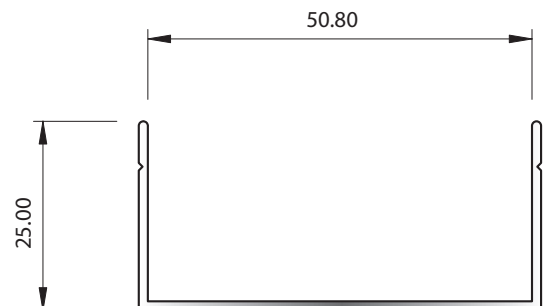

SECTION No. 9056
0.324 kg/m
P = 203.00

For NZ based customers. All lengths are stocked in 6060 T5 - mill finish - 5m lengths (unless specified)
All peripheries less than 100mm are deemed 100mm for surface finish purpose

Coolstore

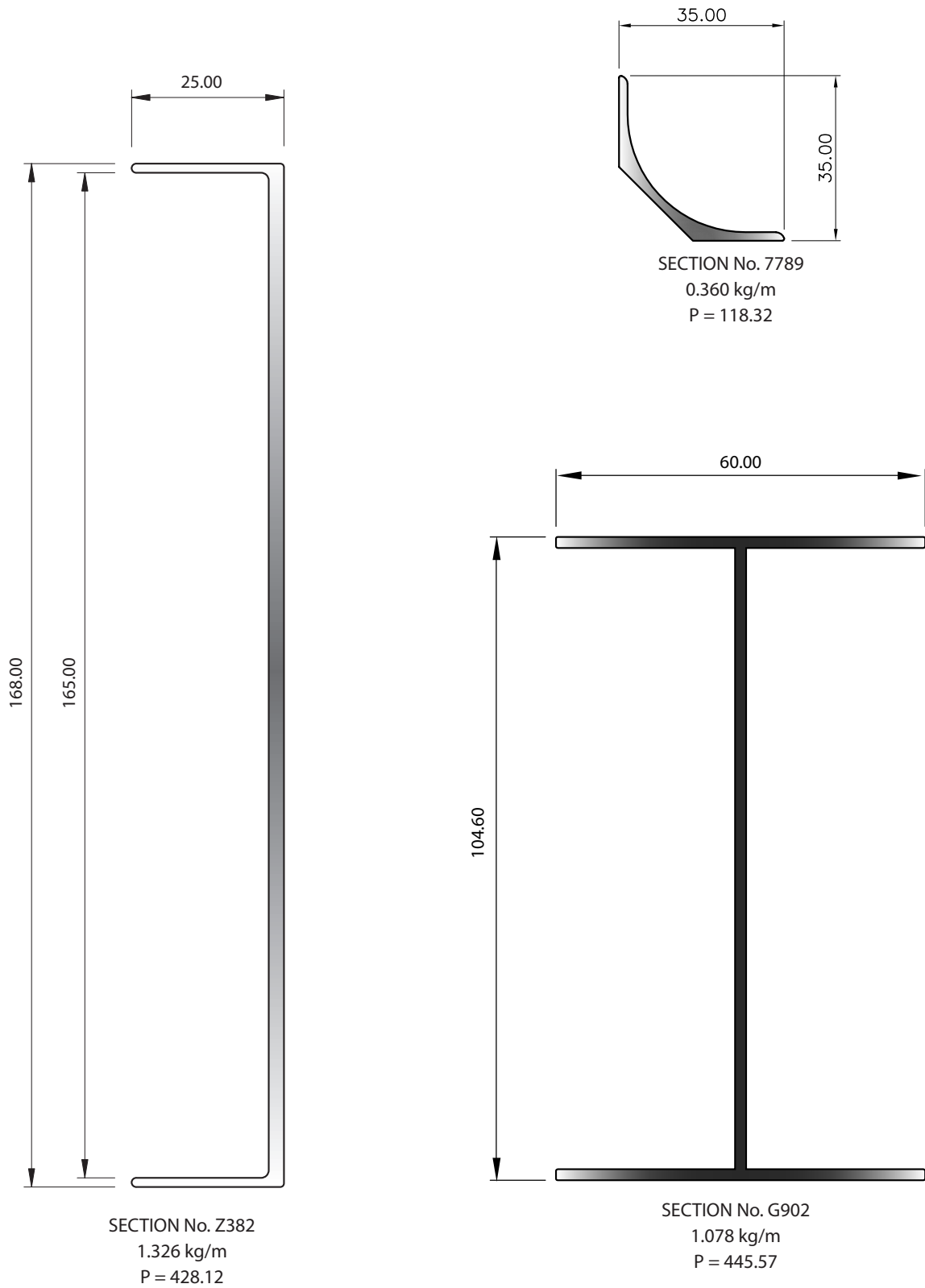

For NZ based customers. All lengths are stocked in 6060 T5 - mill finish - 5m lengths (unless specified)
All peripheries less than 100mm are deemed 100mm for surface finish purpose

Coolstore

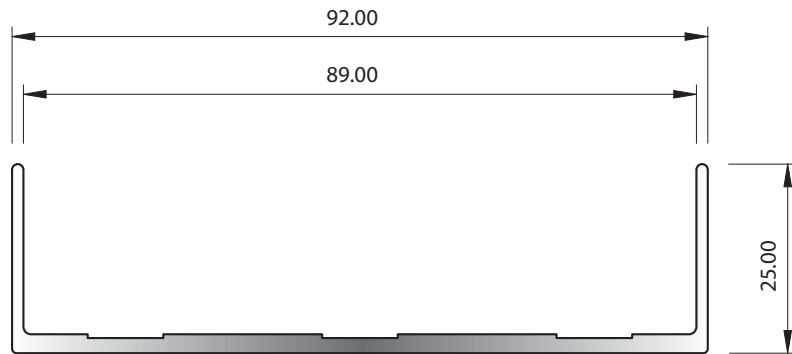

SECTION No. Z381

0.769 kg/m

P = 279.34

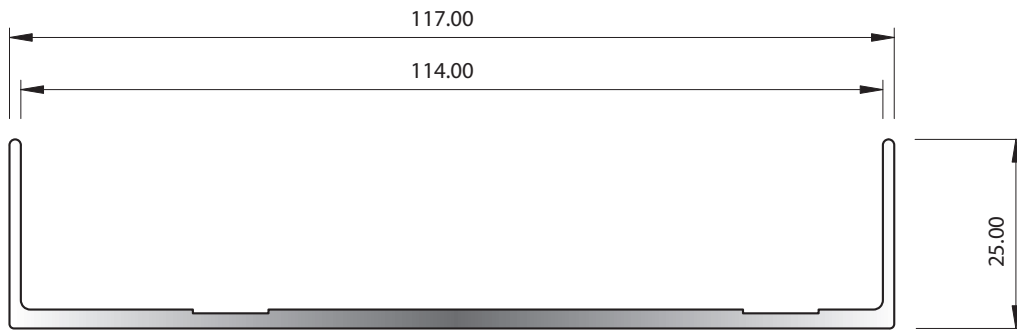

SECTION No. Z383

0.953 kg/m

P = 328.12

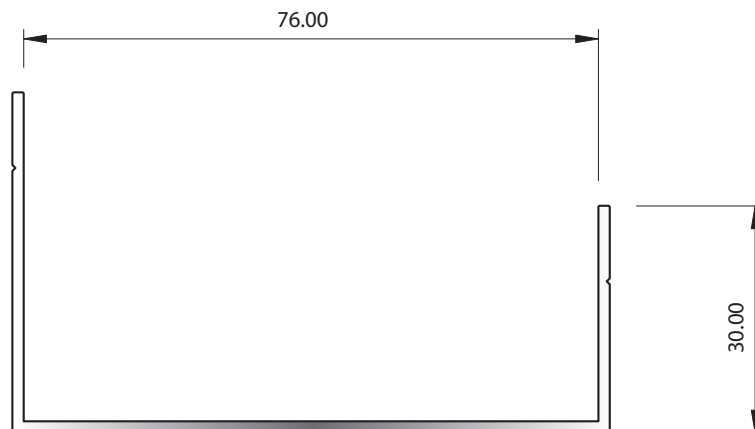

SECTION No. 31347

0.614 kg/m

P = 304.48

For NZ based customers. All lengths are stocked in 6060 T5 - mill finish - 5m lengths (unless specified)
All peripheries less than 100mm are deemed 100mm for surface finish purpose

Coolstore

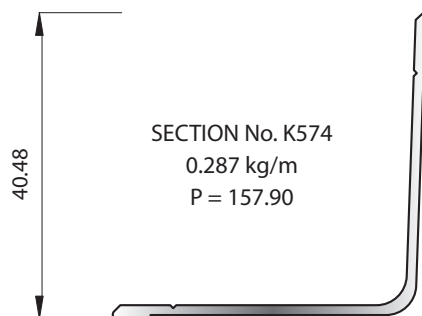
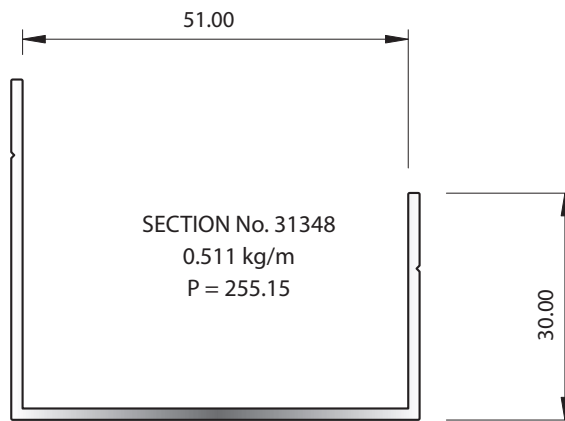
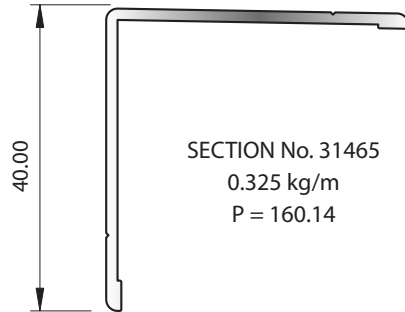

For NZ based customers. All lengths are stocked in 6060 T5 - mill finish - 5m lengths (unless specified)
All peripheries less than 100mm are deemed 100mm for surface finish purpose

Coolstore

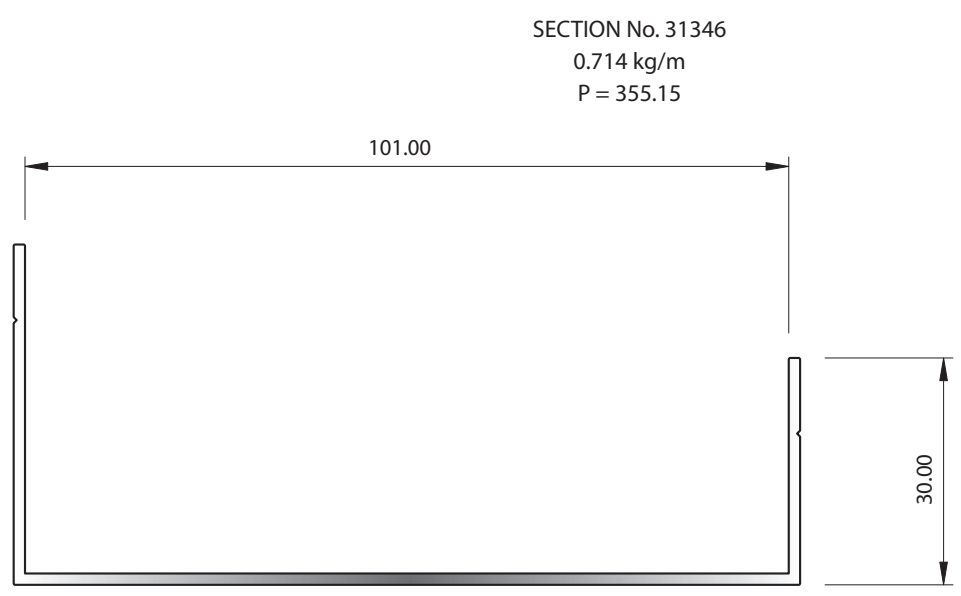
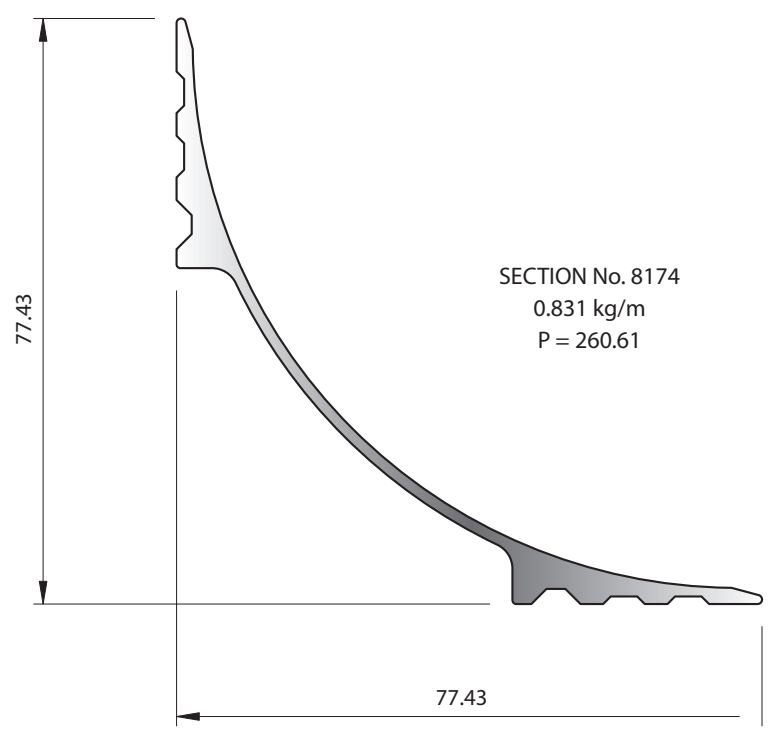

For NZ based customers. All lengths are stocked in 6060 T5 - mill finish - 5m lengths (unless specified)
All peripheries less than 100mm are deemed 100mm for surface finish purpose

Building Products

McKechnie[®] Sections

Stocked Products

updated April 2024



Wardrobe Suites

SECTION NUMBER	DESCRIPTION	MASS kg/m	OUTSIDE PERIM
33947 [!]	Fixing Rail	0.474	118.61
33952	Top Track	0.293	167.68
33953	Top Track	0.587	280.10
33954	Top Track	0.880	392.51
33955	Bottom Track	0.220	120.72
33956	Bottom Track	0.382	205.55
33957	Bottom Track	0.543	290.37
33958	Top Rail	0.391	140.03
33959	Bottom Rail	0.592	292.46
33960~	Stile	0.516	199.03
34069 ⁺	Euro Hanging Rail	0.459	91.18
36157 ⁺	Wardrobe Hanging Rail	0.310	76.58
9250	Top Track	0.431	246.63
9251	Bottom Track	0.217	136.10
N923	Bottom Track	0.370	230.10
N924	Top Track	0.745	409.90
Z439	Top and Bottom Rail	0.285	106.40
Z447 [*]	Stile	0.282	165.46
K068	Wardrobe Rail	0.564	266.60

~ Also available in anodised 4.8m lengths

* Available in 4.8m lengths only

+ Available in anodised only

! Also available in white satin

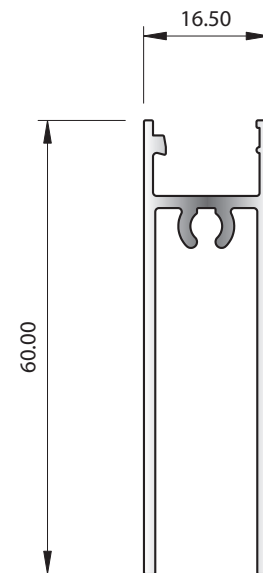

SECTION No. 33959

0.592 kg/m

P = 292.46

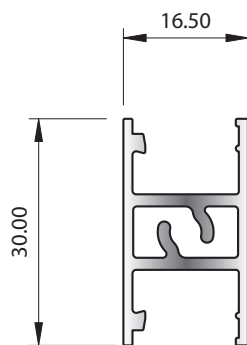

SECTION No. 33958

0.391 kg/m

P = 140.03

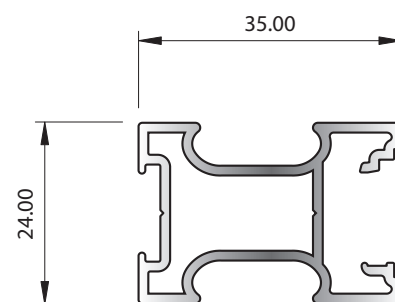

SECTION No. 33960

0.516 kg/m

P = 199.03

For NZ based customers. All lengths are stocked in 6060 T5 - mill finish - 5m lengths (unless specified)
All peripheries less than 100mm are deemed 100mm for surface finish purpose

Wardrobe Suites

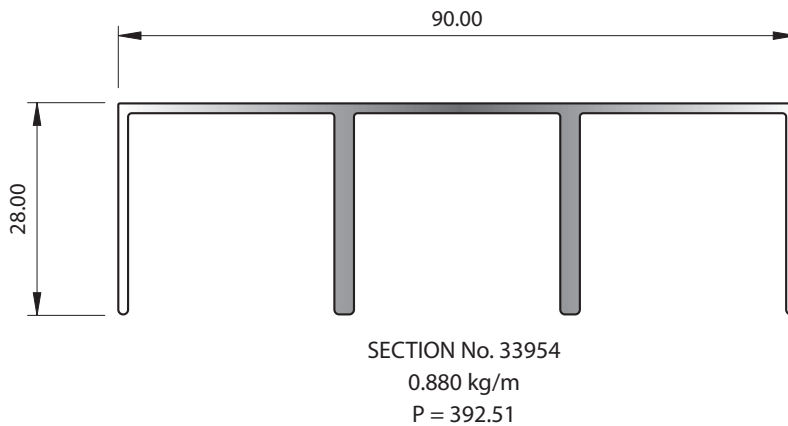
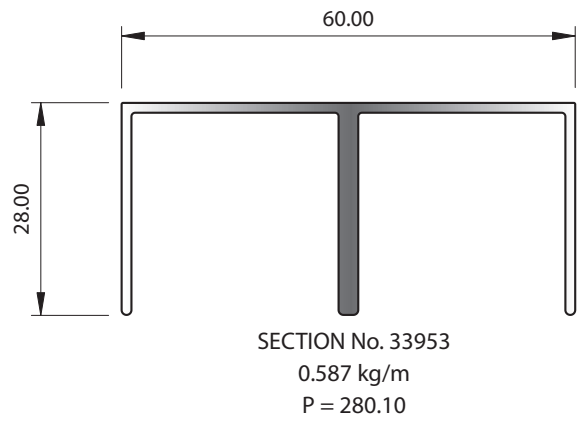
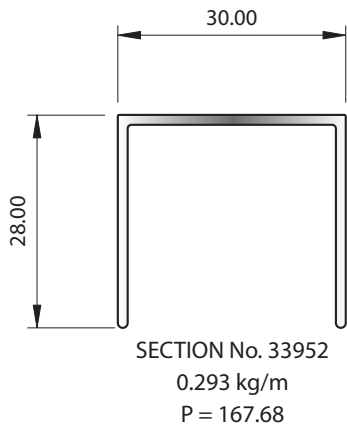
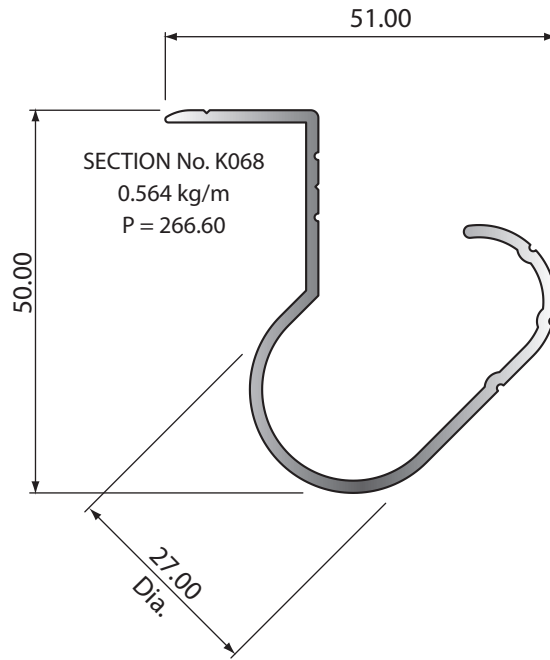

For NZ based customers. All lengths are stocked in 6060 T5 - mill finish - 5m lengths (unless specified)
All peripheries less than 100mm are deemed 100mm for surface finish purpose

Wardrobe Suites

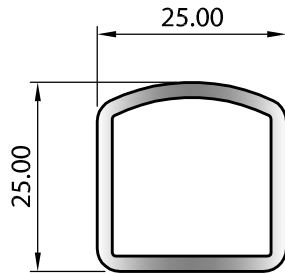

SECTION No. 34069
0.459 kg/m
P = 91.18

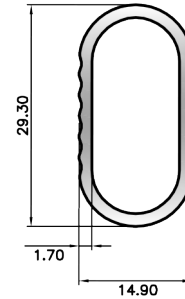

SECTION No. 36157
0.310 kg/m
P = 76.58

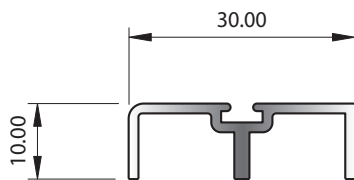

SECTION No. 33955
0.220 kg/m
P = 120.72

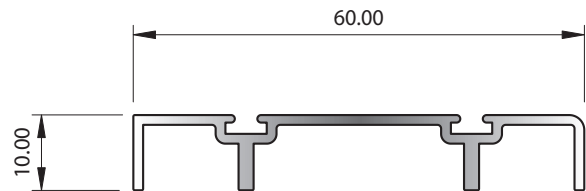

SECTION No. 33956
0.382 kg/m
P = 205.55

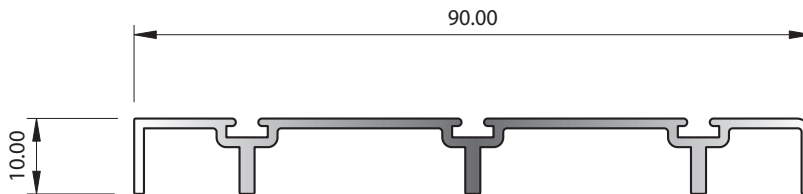

SECTION No. 33957
0.543 kg/m
P = 290.37

For NZ based customers. All lengths are stocked in 6060 T5 - mill finish - 5m lengths (unless specified)
All peripheries less than 100mm are deemed 100mm for surface finish purpose

Wardrobe Suites

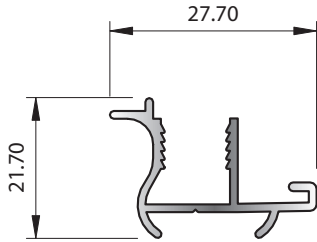

SECTION No. Z447
0.282 kg/m
P = 165.46

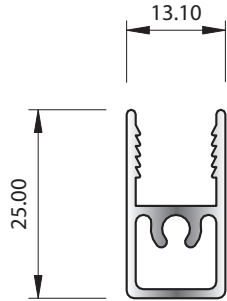

SECTION No. Z439
0.285 kg/m
P = 106.40

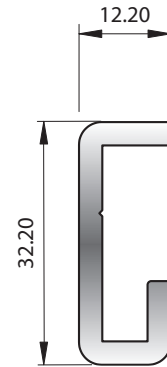

SECTION No. 33947
0.474 kg/m
P = 118.61

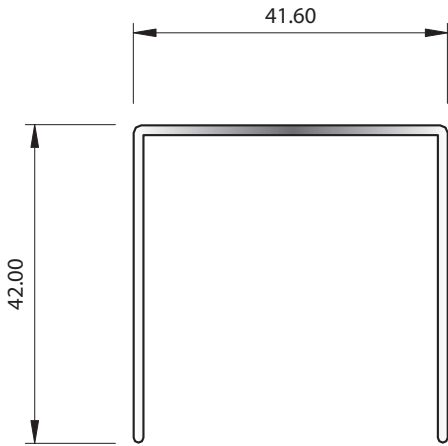

SECTION No. 9250
0.431 kg/m
P = 246.63

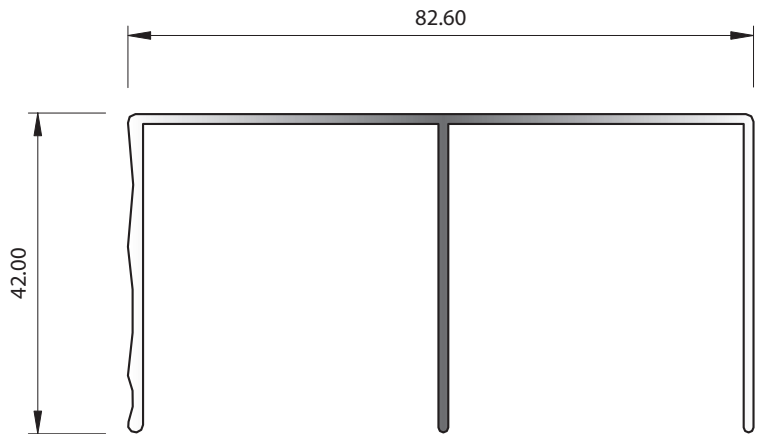

SECTION No. N924
0.745 kg/m
P = 409.90

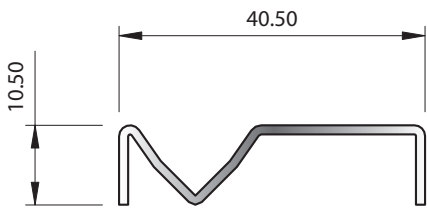

SECTION No. 9251
0.217 kg/m
P = 136.10

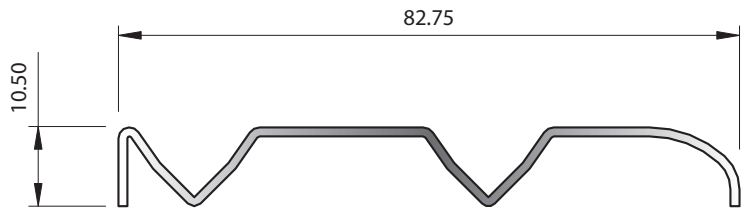

SECTION No. N923
0.370 kg/m
P = 230.10

For NZ based customers. All lengths are stocked in 6060 T5 - mill finish - 5m lengths (unless specified)
All peripheries less than 100mm are deemed 100mm for surface finish purpose

Internal Glazing

SECTION NUMBER	MASS kg/m	OUTSIDE PERIM	LENGTH	STOCKED IN ANODISED
33602	0.353	178.41	5.00	
33603	0.278	141.75	5.00	
33604	0.742	275.99	5.00	
33605	0.160	91.28	5.00	
5620	0.484	157.03	5.00	CHCH ONLY
5653	0.166	97.50	5.00	✓
Z661+	0.184	114.92	5.60	✓
Z662+	0.442	207.66	5.60	✓

+ Stocked in anodised finish only

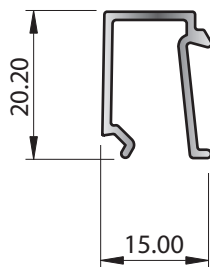

SECTION No. Z661
0.184 kg/m
P = 114.92

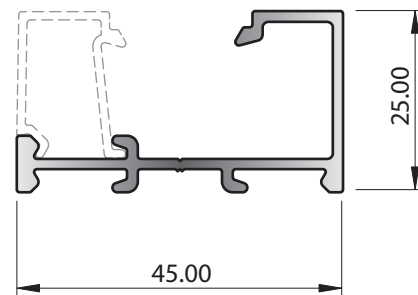

SECTION No. Z662
0.442 kg/m
P = 207.66

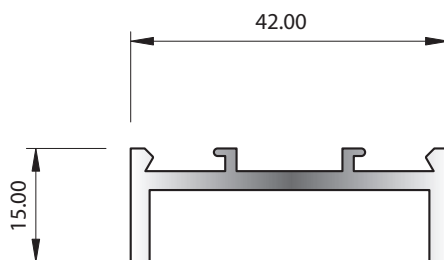

SECTION No. 5620
0.484 kg/m
P = 157.03

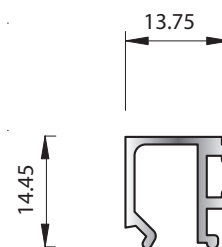

SECTION No. 5653
0.166 kg/m
P = 97.50

For NZ based customers. All lengths are stocked in 6060 T5 - mill finish - 5m lengths (unless specified)
All peripheries less than 100mm are deemed 100mm for surface finish purpose

Internal Glazing

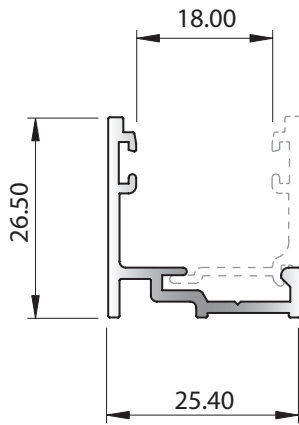

SECTION No. 33603
0.278 kg/m
P = 141.75

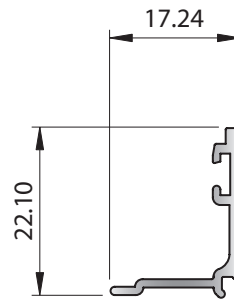

SECTION No. 33605
0.160 kg/m
P = 91.28

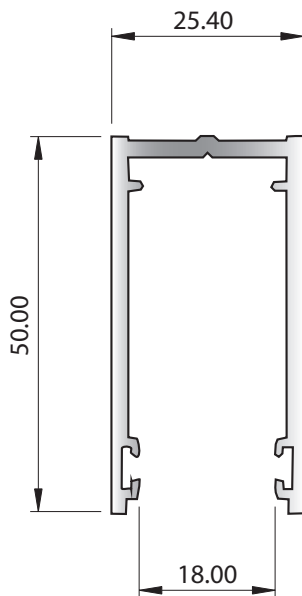

SECTION No. 33604
0.742 kg/m
P = 275.99

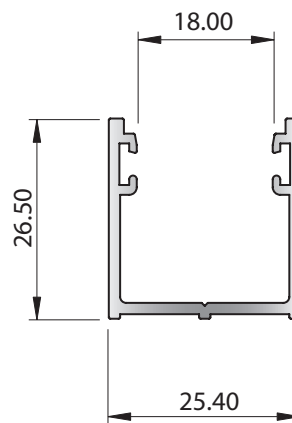

SECTION No. 33602
0.353 kg/m
P = 178.41

For NZ based customers. All lengths are stocked in 6060 T5 - mill finish - 5m lengths (unless specified)
All peripheries less than 100mm are deemed 100mm for surface finish purpose

Head Flashings, Sill Pans & Adaptors

Head Flashings

SECTION NUMBER	"XX"	MASS kg/m	OUTSIDE PERIM
35360	10.00	0.281	183.89
35361	15.00	0.298	194.38
35362	20.00	0.315	204.74
35363	25.00	0.332	215.09
35364	30.00	0.348	225.44
35365	35.00	0.379	235.87
35366	40.00	0.397	246.26
35300	45.00	0.429	256.70
35301	50.00	0.448	267.05
35302*	55.00	0.464	275.46
35484	60.00	0.484	287.75
35367	65.00	0.530	290.81
35368*	70.00	0.557	308.24
35369*	75.00	0.578	319.01
36814	80.00	0.597	329.36
37069†	85.00	0.617	339.71
37070†	90.00	0.637	350.07
37080†	95.00	0.704	360.51

* 6m lengths only

†5m lengths only

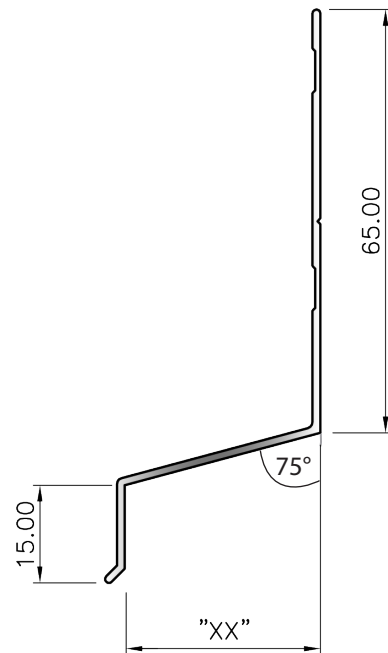

Sill Pans

SECTION NUMBER	"XX"	MASS kg/m	OUTSIDE PERIM
35303	66.00	0.495	251.13
35962	84.00	0.568	287.13
35432	105.30	0.694	329.92

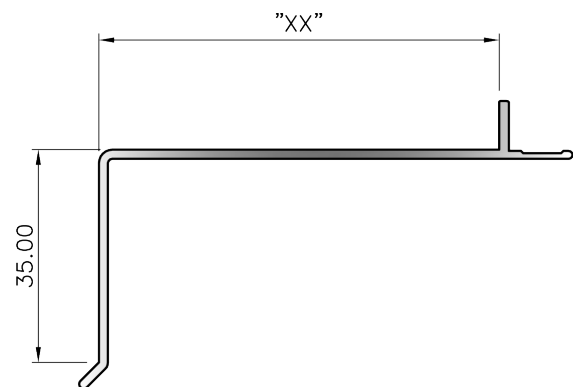

Adaptors

SECTION NUMBER	MASS kg/m	OUTSIDE PERIM
50212	0.525	172.96
50285	0.552	209.91

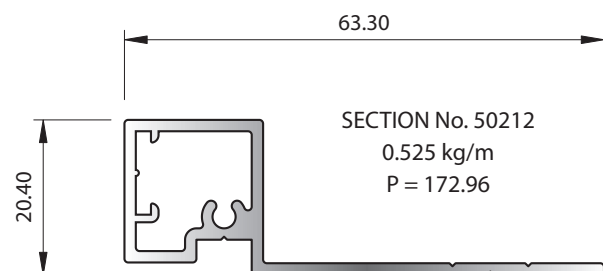
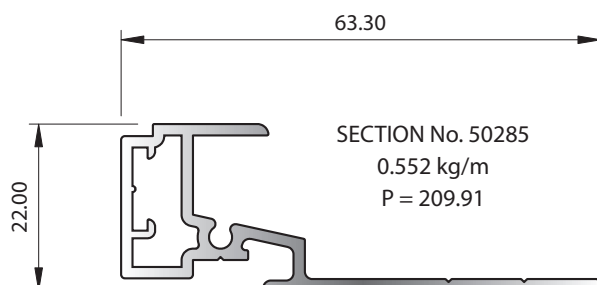

For NZ based customers. All lengths are stocked in 6060 T5 - mill finish - 5m lengths (unless specified)
All peripheries less than 100mm are deemed 100mm for surface finish purpose

WANZ Sill Support Bars

SECTION NUMBER	NEW WANZ BARS (Pending)	DESCRIPTION	LENGTH
34649D	36352 (0.525 kg/m)	19mm Sill Support Bar	5.00
34648D	36353 (0.591 kg/m)	30mm Sill Support Bar	5.00
34647D	36354 (0.793 kg/m)	40mm Sill Support Bar	5.00
34370D	-	55mm Sill Support Bar	5.00
35298D	36355 (0.978 kg/m)	55mm Sill Support Bar	5.00
35299D	36356 (1.173 kg/m)	55mm Full Length Sill Support Bar	5.00

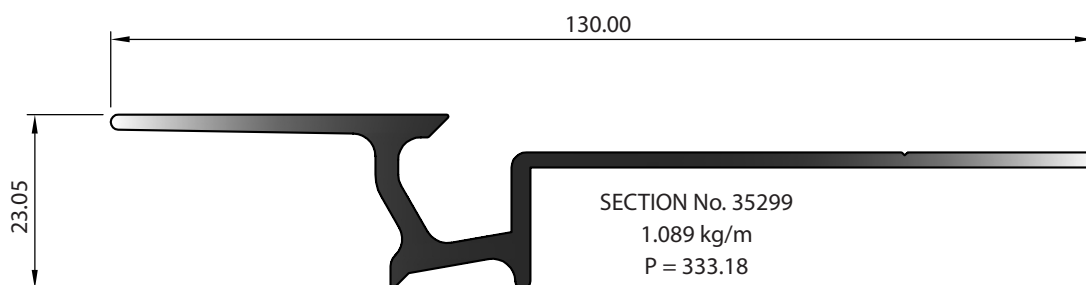
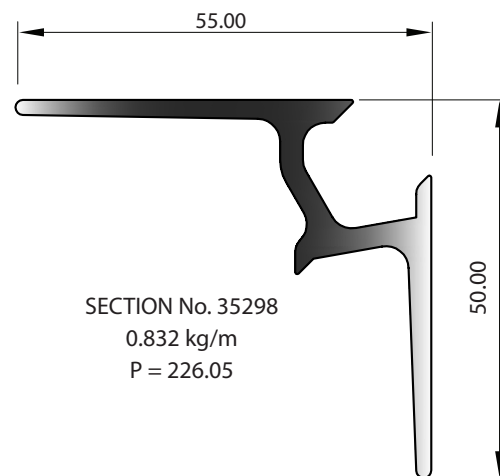
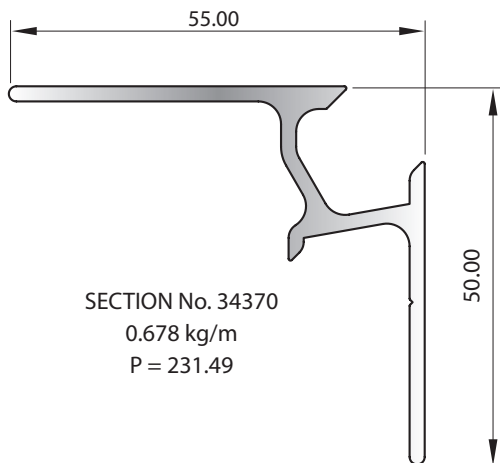
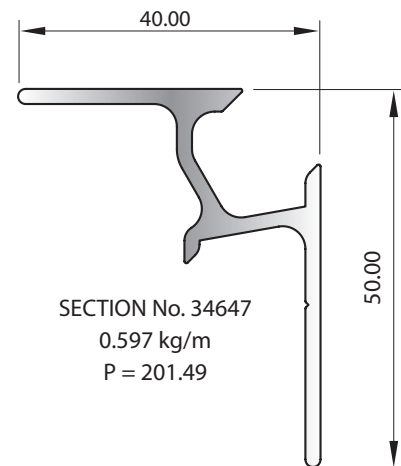
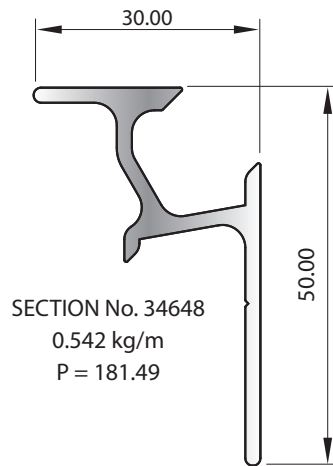
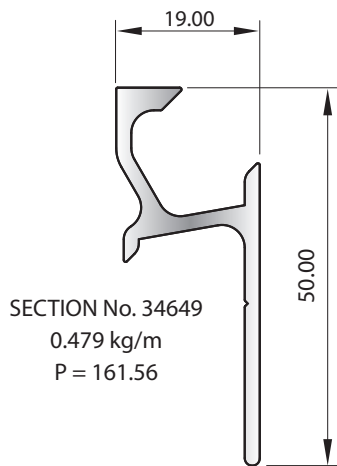

For NZ based customers. All lengths are stocked in 6060 T5 - mill finish - 5m lengths (unless specified)
All peripheries less than 100mm are deemed 100mm for surface finish purpose

Retrofit Double Glazing

SECTION NUMBER	DESCRIPTION	MASS kg/m	OUTSIDE PERIM
34132	Sash	0.731	286.27
34244	Adaptor	0.501	222.81
34245	Bead	0.155	95.43
34461	Adaptor	0.426	220.09
34462	Adaptor	0.346	220.59
34463	Sash	0.744	271.28
34732	Bead	0.154	90.09
34733	Bead	0.132	88.11
34734	Bead	0.148	86.26
34735	Bead	0.209	130.26
34736	Bead	0.194	100.54
34737	Bead	0.184	100.21
36116	Bead	0.163	93.21
36117	Bead	0.275	155.35
36118	Bead	0.137	85.96
36119-A	Bead	0.154	103.20
36120	Bead	0.151	93.75
36483	Sash	0.718	285.67
38703	Sash	0.796	313.05
37864	Bead	0.274	178.09
37866	Bead	0.167	94.55
37868	Bead	0.151	101.86
37999 *	Adaptor	0.333	173.66

* Replaced Section 34006

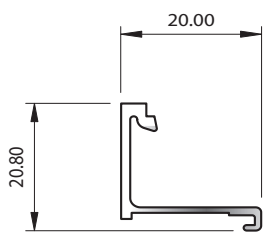

SECTION No. 34245
0.155 kg/m
P = 95.43

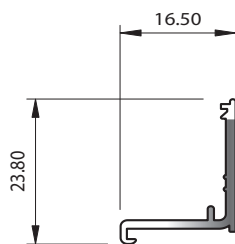

SECTION No. 34732
0.154 kg/m
P = 90.09

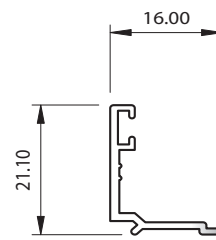

SECTION No. 34733
0.132 kg/m
P = 88.11

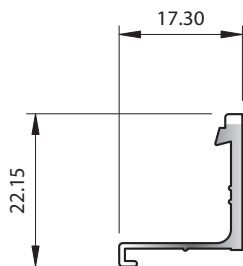

SECTION No. 34734
0.148 kg/m
P = 86.26

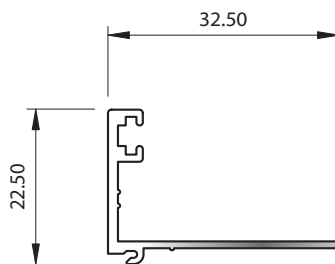

SECTION No. 34735
0.209 kg/m
P = 130.26

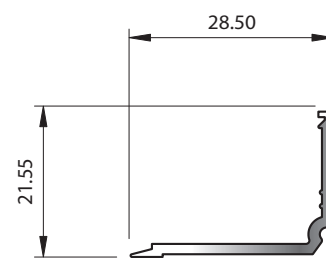

SECTION No. 34736
0.194 kg/m
P = 100.54

Retrofit Double Glazing

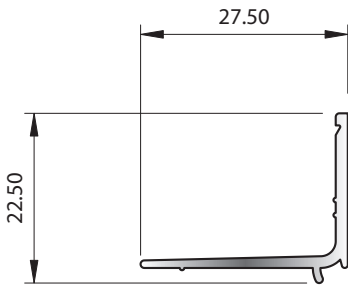

SECTION No. 34737
0.184 kg/m
P = 100.21

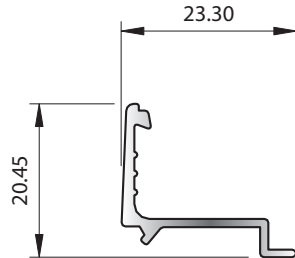

SECTION No. 36116
0.163 kg/m
P = 93.21

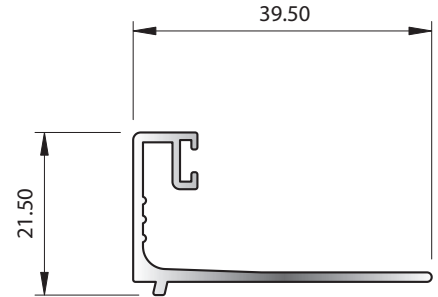

SECTION No. 36117
0.275 kg/m
P = 155.35

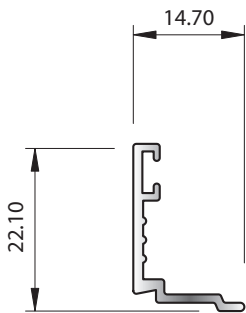

SECTION No. 36118
0.137 kg/m
P = 85.96

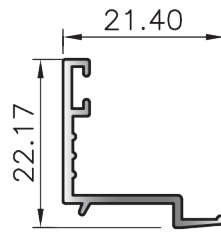

SECTION No. 36119A
0.154 kg/m
P = 103.20

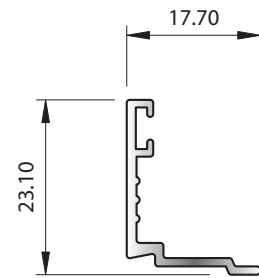

SECTION No. 36120
0.151 kg/m
P = 93.75

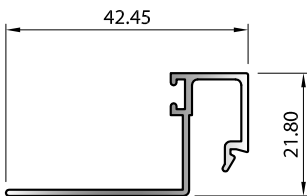

SECTION No. 37864
0.274 kg/m
P = 178.09

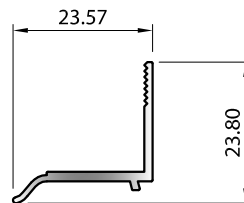

SECTION No. 37866
0.167 kg/m
P = 94.55

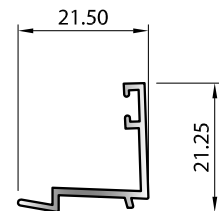

SECTION No. 37868
0.151 kg/m
P = 101.86

For NZ based customers. All lengths are stocked in 6060 T5 - mill finish - 5m lengths (unless specified)
All peripheries less than 100mm are deemed 100mm for surface finish purpose

Retrofit Double Glazing

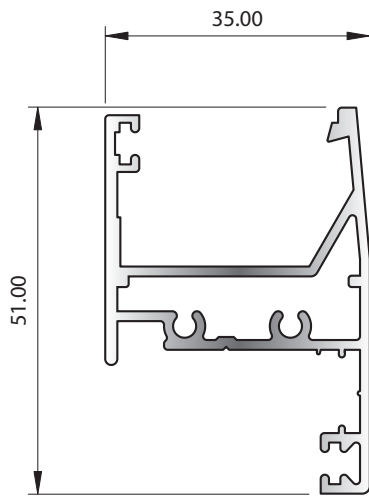

SECTION No. 34463
0.744 kg/m
P = 271.28

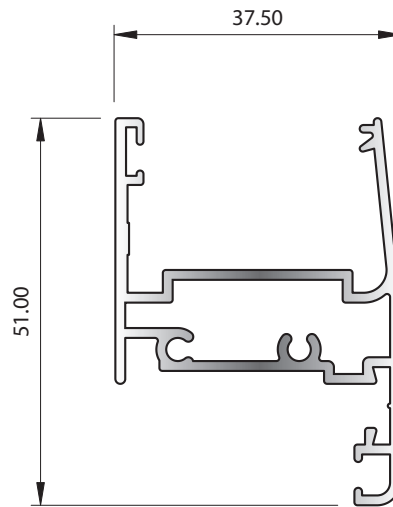

SECTION No. 34132
0.731 kg/m
P = 286.27

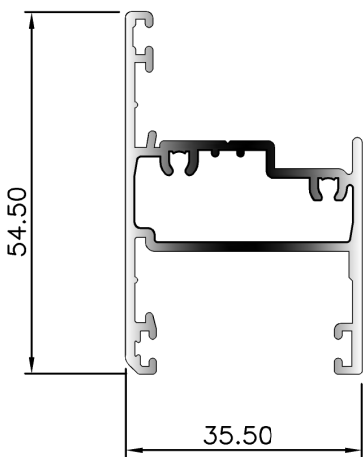

SECTION No. 36483
0.718 kg/m
P = 285.67

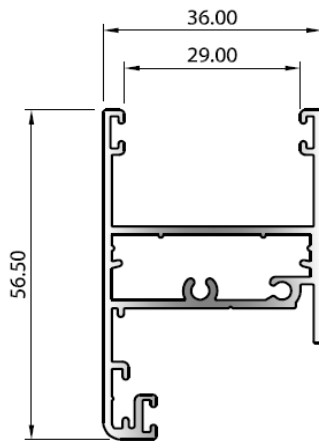

SECTION No. 38703
0.796 kg/m
P = 313.05

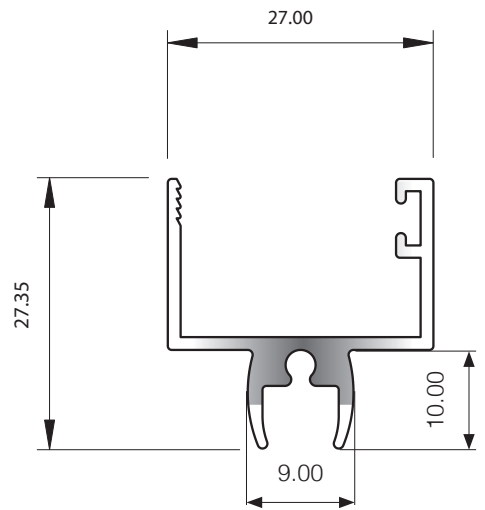

SECTION No. 37999
0.333 kg/m
P = 173.66

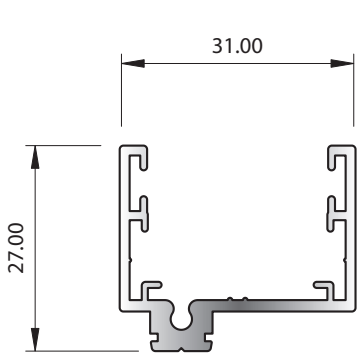

SECTION No. 34461
0.426 kg/m
P = 220.09

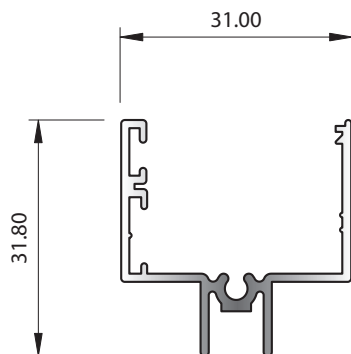

SECTION No. 34462
0.346 kg/m
P = 220.59

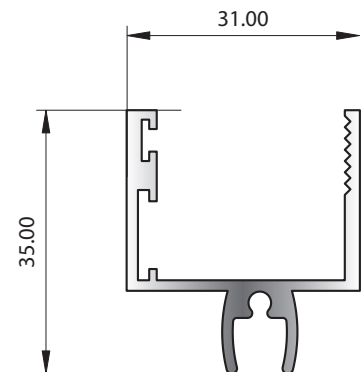

SECTION No. 34244
0.501 kg/m
P = 222.81

For NZ based customers. All lengths are stocked in 6060 T5 - mill finish - 5m lengths (unless specified)
All peripheries less than 100mm are deemed 100mm for surface finish purpose

Security & Grille

SECTION NUMBER	MASS kg/m	OUTSIDE PERIM	LENGTH
5663	0.351	143.50	5.00
5979	0.194	92.80	5.00
6136+	0.150	72.23	5.00
6179	0.450	194.42	5.00
30973	0.421	210.39	5.00
31701	0.589	230.62	6.00
33423 +	0.744	227.67	6.00
33627	0.483	217.96	4.60
33628	0.936	295.94	4.60
33629	0.483	217.75	4.60
33630 +	1.200	369.10	6.00
34689	1.521	453.62	4.60
38959 #	0.115	100.00	3.00
36405	0.154	87.09	3.00
37488	0.109	77.13	5.00
37523	0.804	237.92	6.00
G253	0.50	194.49	5.00
J007D +	1.022	320.58	5.00
K803	0.158	87.40	5.00
K804	0.106	56.70	5.00
K805	0.116	62.50	5.00
X574	0.249	126.32	5.00
Z340 +	0.751	240.51	6.00
Z785 +	0.748	240.25	5.00
Z785G	PUNCHED	RIGHT	3.00
Z785H	PUNCHED	LEFT	3.00

+ Also available in 3.0m lengths
 # Available in powder coat matt black only

DETAIL 'A'

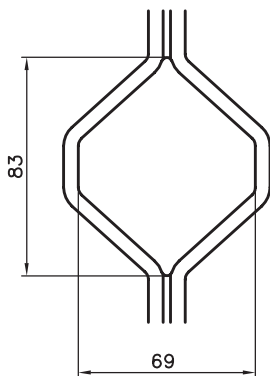

"007"
STYLE MESH

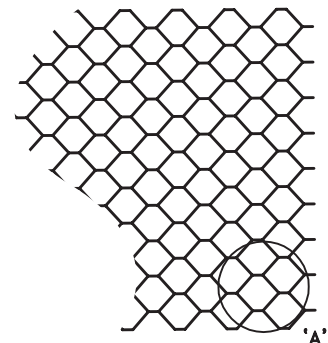

Hardware

ITEM NUMBER	DESCRIPTION
660000	DOOR HANDLE - WHITE
660001	DOOR HANDLE - BLACK
660002	5 PIN CYLINDER
660003	3 POINT LOCK KIT
660004	75mm DOOR HINGE - WHITE
660005	75mm DOOR HINGE - BLACK
660006	LEICHHARDT SLIDING DOOR LOCK
660007	WHEELS FOR SECURITY DOOR
660010	PATIO BOLT
661007	UBE LOCK
662107	WHEELS FOR 9775 FLYSCREEN DOOR

"007" STYLE SIZES	WAREHOUSE	
	NEW PLYMOUTH	CHRISTCHURCH
2000mm x 750mm	✓	✓
4000mm x 750mm	✓	✓
2000mm x 920mm	✓	✓
2455mm x 1200mm	✓	
2000mm x 1250mm	✓	✓
4000mm x 1250mm	✓	✓

CORNER STAKES	FITS SECTION
6868K	Z785, 33423
6868E	Z340
6868L	31701
X124G	5663, 6179
X124L	G253

For NZ based customers. All lengths are stocked in 6060 T5 - mill finish - 5m lengths (unless specified)
 All peripheries less than 100mm are deemed 100mm for surface finish purpose

Security & Grille

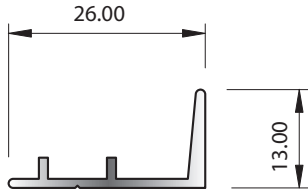

SECTION No. K803
0.158 kg/m
P = 87.40

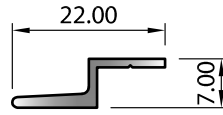

SECTION No. K804
ACCEPTS ANGLE 7084
0.106 kg/m
P = 56.70

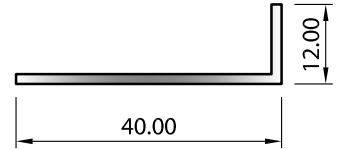

SECTION No. 7084
0.205 kg/m
P = 104

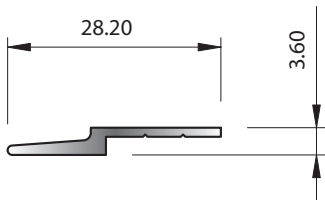

SECTION No. K805
0.116 kg/m
P = 62.50

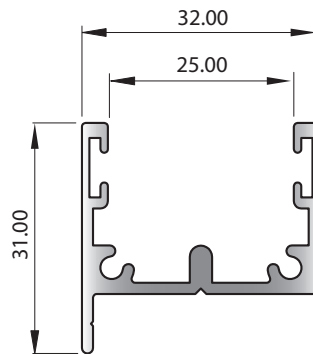

SECTION No. 33627
0.483 kg/m
P = 217.96
LENGTH = 4.6m

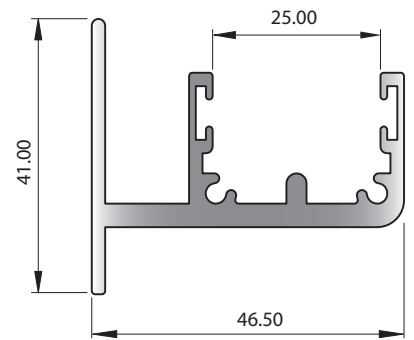

SECTION No. 33628
0.936 kg/m
P = 295.94
LENGTH = 4.6m

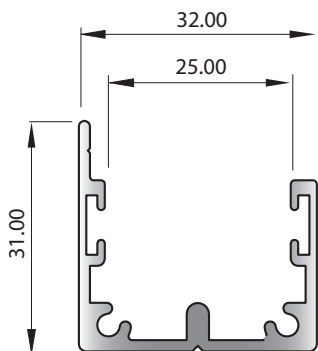

SECTION No. 33629
0.483 kg/m
P = 217.75
LENGTH = 4.6m

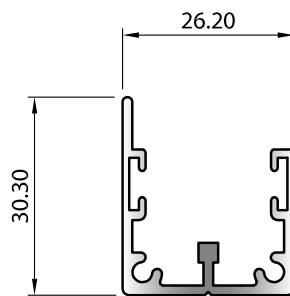

SECTION No. 30973
0.421 kg/m
P = 210.39

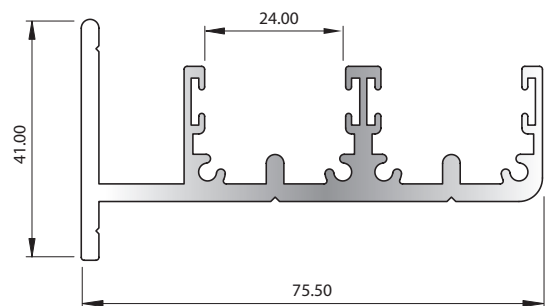

SECTION No. 34689
1.521 kg/m
P = 453.62
LENGTH = 4.6m

For NZ based customers. All lengths are stocked in 6060 T5 - mill finish - 5m lengths (unless specified)
All peripheries less than 100mm are deemed 100mm for surface finish purpose

Security & Grille

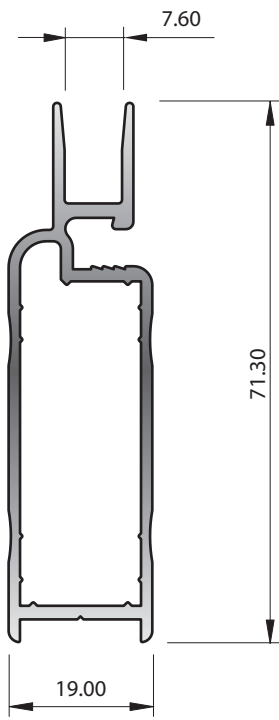

SECTION No. 33423
ACCEPTS STAKING ANGLE 6868K
0.744 kg/m
P = 227.67

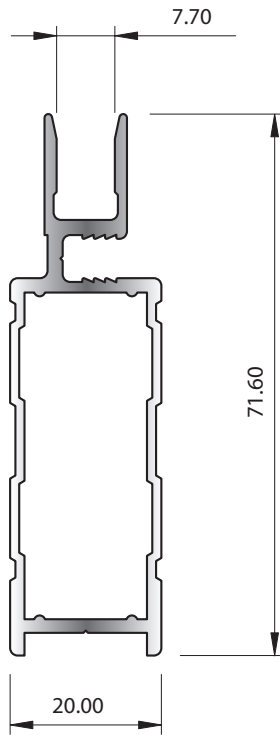

SECTION No. Z340
ACCEPTS STAKING ANGLE 6868E
0.751 kg/m
P = 240.51

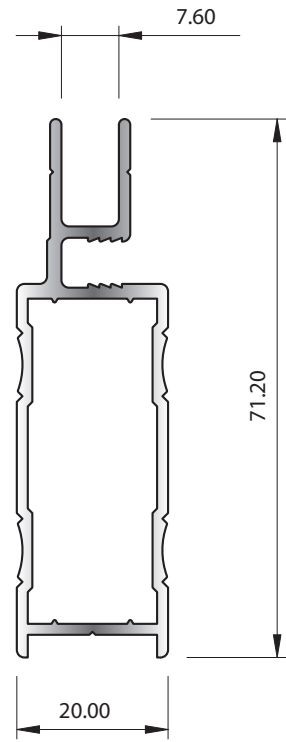

SECTION No. Z785
ACCEPTS STAKING ANGLE 6868K
0.748 kg/m
P = 240.25

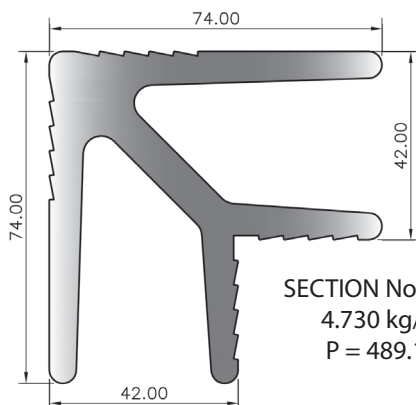

SECTION No. 6868
4.730 kg/m
P = 489.18

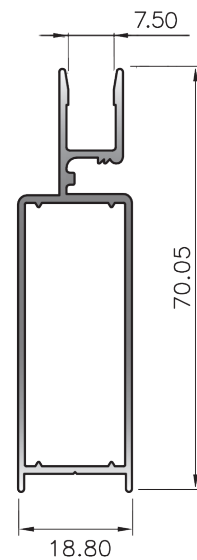

SECTION No. 31701
0.589 kg/m
P = 230.62
ACCEPTS STAKING ANGLE 6868L

For NZ based customers. All lengths are stocked in 6060 T5 - mill finish - 5m lengths (unless specified)
All peripheries less than 100mm are deemed 100mm for surface finish purpose

Security & Grille

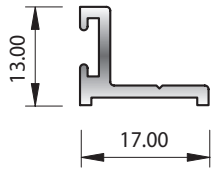

SECTION No. 6136
0.150 kg/m
P = 72.23

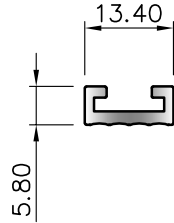

SECTION No. 38959
0.115 kg/m
P = 100

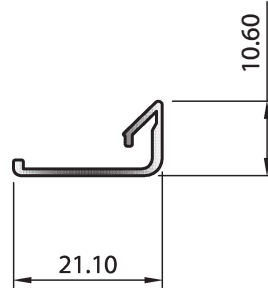

SECTION No. 37488
0.109 kg/m
P = 77.13

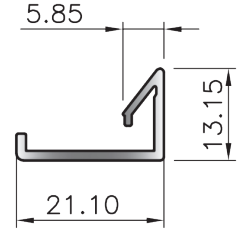

SECTION No. 36405
0.154 kg/m
P = 87.09

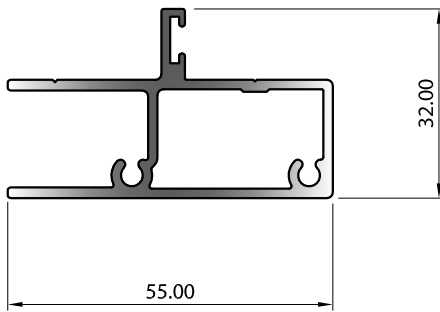

SECTION No. 37523
0.804 kg/m
P = 237.92

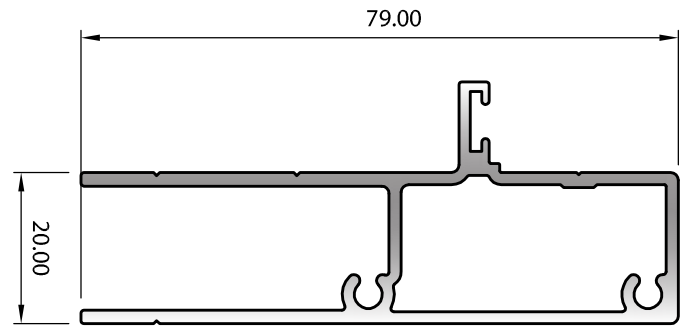

SECTION No. J007D
1.022 kg/m
P = 320.58

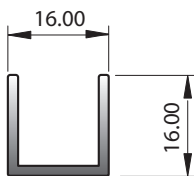

SECTION No. 5979
0.194 kg/m
P = 92.80

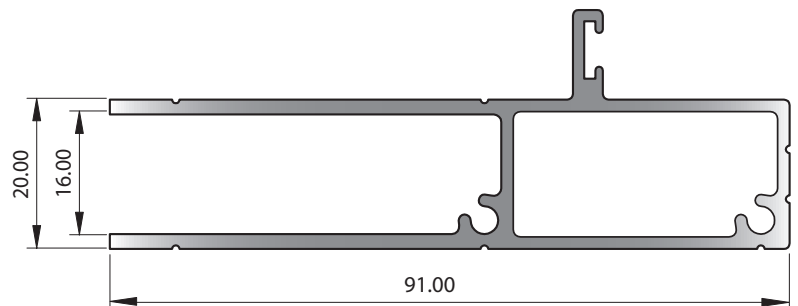

SECTION No. 33630
1.200 kg/m
P = 369.10

For NZ based customers. All lengths are stocked in 6060 T5 - mill finish - 5m lengths (unless specified)
All peripheries less than 100mm are deemed 100mm for surface finish purpose

Security & Grille

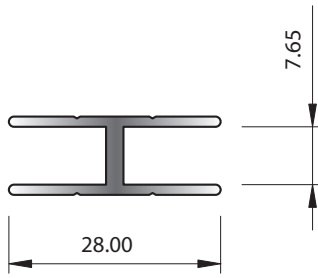

SECTION No. X574
0.249 kg/m
P = 126.32

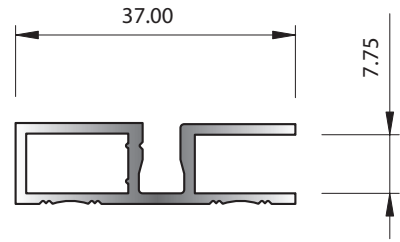

SECTION No. 5663
ACCEPTS STAKING ANGLE X124G
0.351 kg/m
P = 143.50

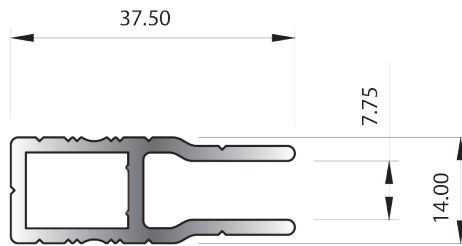

SECTION No. G253
ACCEPTS STAKING ANGLE X124L
0.500 kg/m
P = 194.49

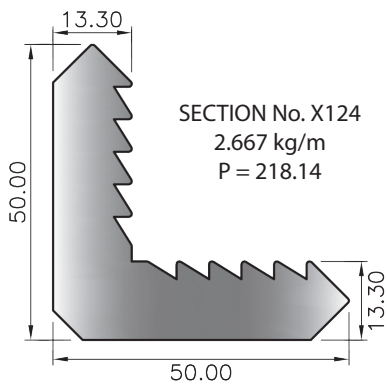

SECTION No. X124
2.667 kg/m
P = 218.14

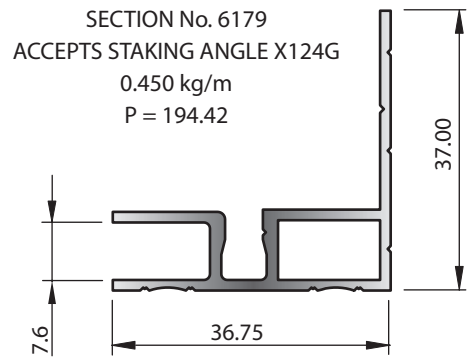

SECTION No. 6179
ACCEPTS STAKING ANGLE X124G
0.450 kg/m
P = 194.42

For NZ based customers. All lengths are stocked in 6060 T5 - mill finish - 5m lengths (unless specified)
All peripheries less than 100mm are deemed 100mm for surface finish purpose

Flyscreen

SECTION NUMBER	MASS kg/m	OUTSIDE PERIM	LENGTH
7675	0.900	334.00	5.00
9775	0.494	150.10	6.00
9775	0.494	150.10	3.00
30957	0.302	117.77	5.00
31017	0.170	98.88	5.00
31018	0.139	81.16	5.00
J030	0.496	199.00	5.00
J031	0.191	94.00	5.00
J032	0.234	118.00	5.00
J058	0.232	94.71	5.00
X075	0.162	98.63	5.00
X076	0.119	79.33	5.00
X389	0.139	71.64	4.00
31966	0.515	156.98	3.00
32605	0.540	262.43	3.00
34918	0.325	143.76	5.00

CORNER STAKES	SUITS SECTION
J688E	9775
X429E	J058, 30957

FLYSCREEN FIBREGLASS MESH	SIZE
662109	76cm x 50m
662110	83cm x 50m
662118	91cm x 30.48m
660014	122cm x 30.48m

Flyscreen fibreglass mesh is sold in rolls only

For NZ based customers. All lengths are stocked in 6060 T5 - mill finish - 5m lengths (unless specified)
All peripheries less than 100mm are deemed 100mm for surface finish purpose

Flyscreen

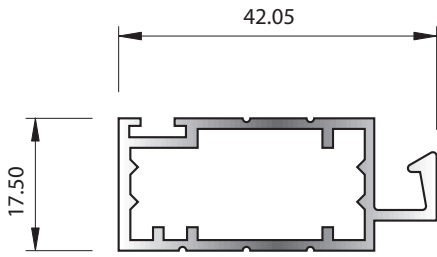

SECTION No. 9775
ACCEPTS STAKING ANGLE J688E
0.494 kg/m
P = 150.10

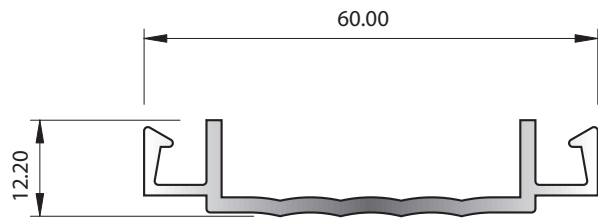

SECTION No. J030
0.496 kg/m
P = 199

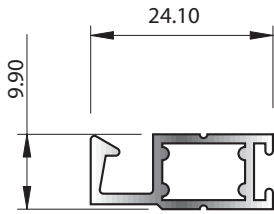

SECTION No. J058
ACCEPTS STAKING ANGLE X429E
0.232 kg/m
P = 94.71

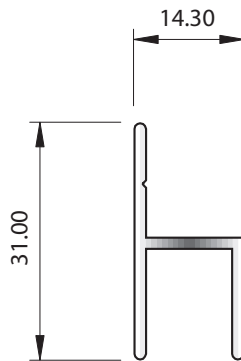

SECTION No. J032
0.234 kg/m
P = 118

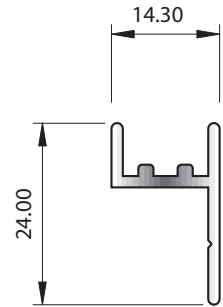

SECTION No. J031
0.191 kg/m
P = 94

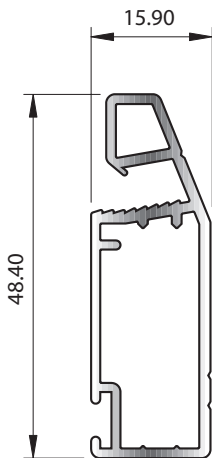

SECTION No. 31966
ACCEPTS STAKING ANGLE J688E
0.515 kg/m
P = 156.98

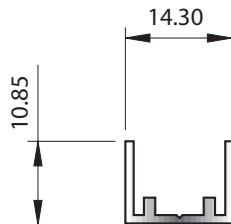

SECTION No. X076
0.119 kg/m
P = 79.33

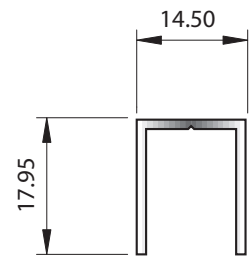

SECTION No. X075
0.162 kg/m
P = 98.63

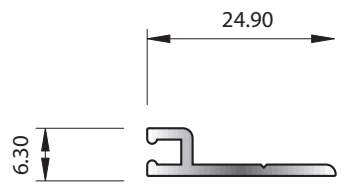

SECTION No. X389
0.139 kg/m
P = 71.64

For NZ based customers. All lengths are stocked in 6060 T5 - mill finish - 5m lengths (unless specified)
All peripheries less than 100mm are deemed 100mm for surface finish purpose

Flyscreen

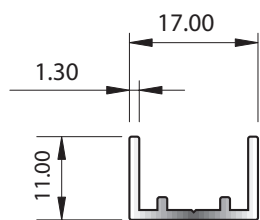

SECTION No. 31018
0.139 kg/m
P = 81.16

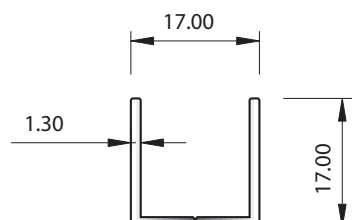

SECTION No. 31017
0.170 kg/m
P = 98.88

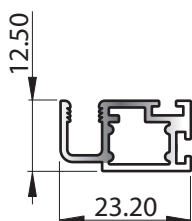

SECTION No. 30957
ACCEPTS STAKING ANGLE X429E
0.302 kg/m
P = 117.77

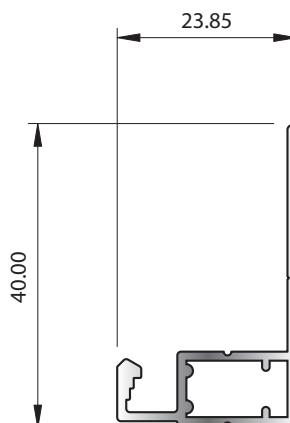

SECTION No. 34918
ACCEPTS STAKING ANGLE X429E
0.325 kg/m
P = 143.76

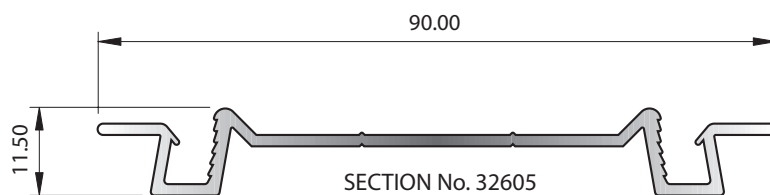

SECTION No. 32605
0.540 kg/m
P = 262.43

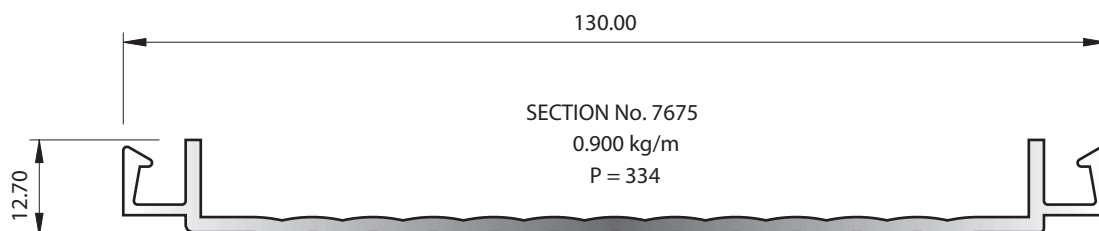

SECTION No. 7675
0.900 kg/m
P = 334

For NZ based customers. All lengths are stocked in 6060 T5 - mill finish - 5m lengths (unless specified)
All peripheries less than 100mm are deemed 100mm for surface finish purpose

Awning

SECTION NUMBER	DESCRIPTION	MASS kg/m	OUTSIDE PERIM	LENGTH	STOCKED IN ANODISED
6595	AWNING TRACK	0.221	95.94	5.00	✓
33601	AWNING TRACK	0.194	103.12	6.00	
34987	AWNING TRACK	0.496	192.36	5.00	
35469	AWNING TRACK	0.561	160.02	5.00	
35511	AWNING FRAME	0.382	125.94	6.00	
35512	2 WAY AWNING FRAME	0.708	211.83	6.00	
34049	ROLLER TUBE	1.253	256.29	6.00	
8955	ROPE TRACK	0.279	129.99	5.00	
TU8240	EXTRUDED TUBE	0.251	62.80	5.00	BRIGHT ANODISED
TU8575	EXTRUDED TUBE	0.562	78.50	5.00	BRIGHT ANODISED

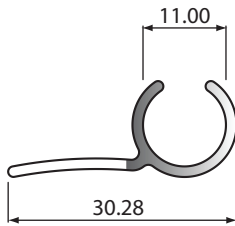

SECTION No. 33601
0.194 kg/m
P = 103.12

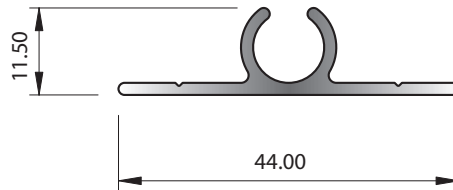

SECTION No. 8955
0.279 kg/m
P = 129.99

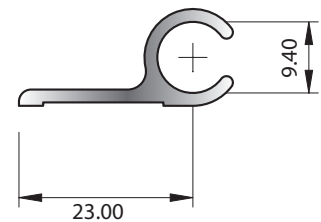

SECTION No. 6595
0.221 kg/m
P = 95.94

For NZ based customers. All lengths are stocked in 6060 T5 - mill finish - 5m lengths (unless specified)
All peripheries less than 100mm are deemed 100mm for surface finish purpose

Awning

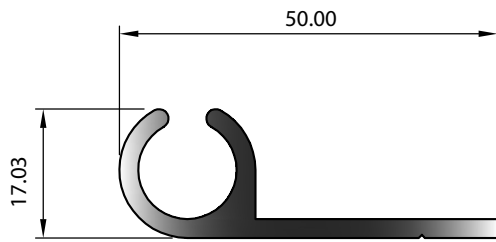

SECTION No. 35469
0.561 kg/m
P = 160.02

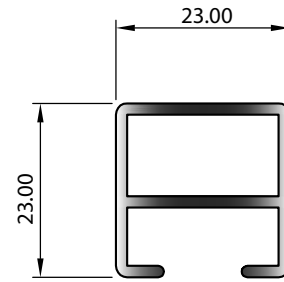

SECTION No. 35511
0.382 kg/m
P = 125.94

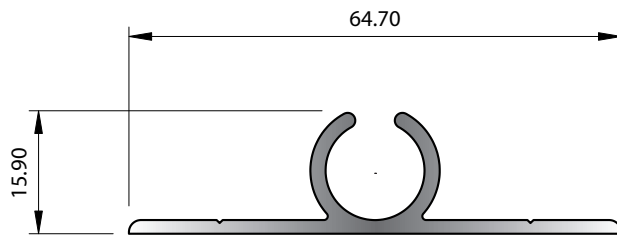

SECTION No. 34987
0.496 kg/m
P = 192.36

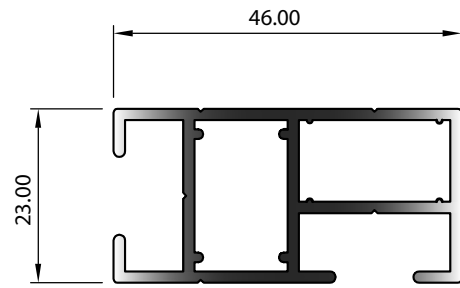

SECTION No. 35512
0.708 kg/m
P = 211.83



SECTION No. 34049
1.253 kg/m
P = 256.29

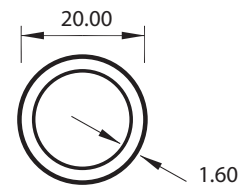

SECTION No. TU8240
0.251 kg/m
P = 62.8

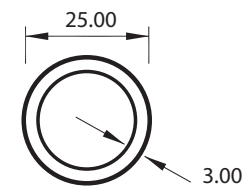

SECTION No. TU8575
0.562 kg/m
P = 78.5

For NZ based customers. All lengths are stocked in 6060 T5 - mill finish - 5m lengths (unless specified)
All peripheries less than 100mm are deemed 100mm for surface finish purpose

Miscellaneous

SECTION NUMBER	DESCRIPTION	MASS kg/m	OUTSIDE PERIM	LENGTH	STOCKED IN ANODISED
34050^	MOBILITY THRESHOLD	0.809	304.98	5.00	✓
0330	MOULD	0.342	88.00	5.00	
8966	COLONIAL BAR	0.143	47.70	5.00	
35242	LIGHT BOX	1.346	503.49	6.00	
35243	LIGHT BOX	1.850	599.95	6.00	
X540^	SIGN FRAME	1.418	528.89	6.00	
7789	COVING	0.360	118.32	5.00	

^ Stocked in Christchurch warehouse only

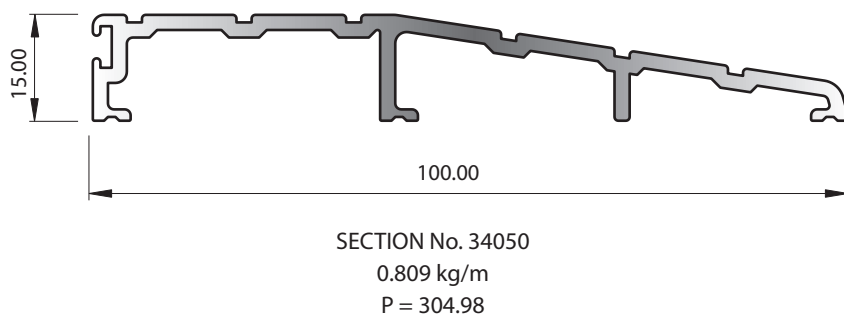
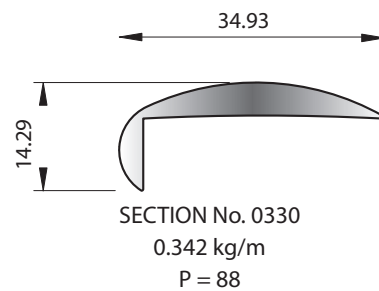
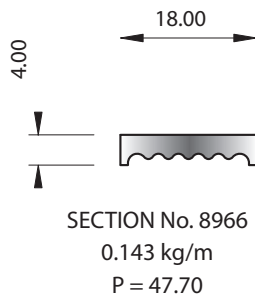

For NZ based customers. All lengths are stocked in 6060 T5 - mill finish - 5m lengths (unless specified)
All peripheries less than 100mm are deemed 100mm for surface finish purpose

Miscellaneous

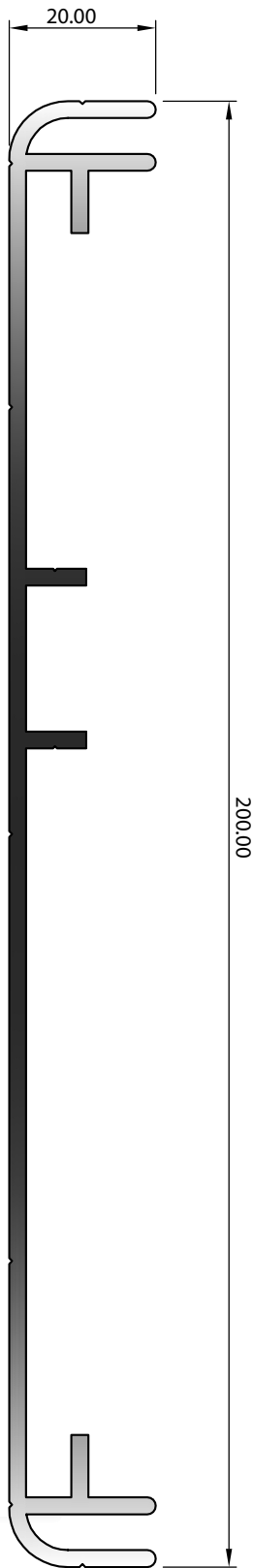

SECTION No. 35243
 1.850 kg/m
 P = 599.95

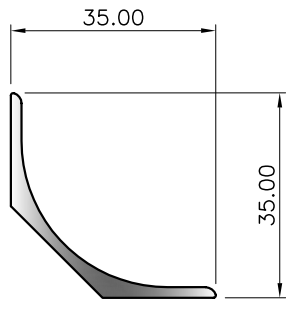

SECTION No. 7789
 0.360 kg/m
 P = 118.32

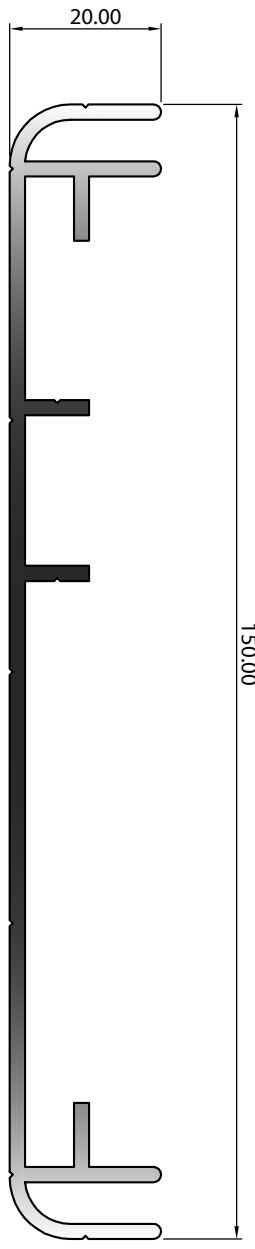

SECTION No. 35242
 1.346 kg/m
 P = 503.49

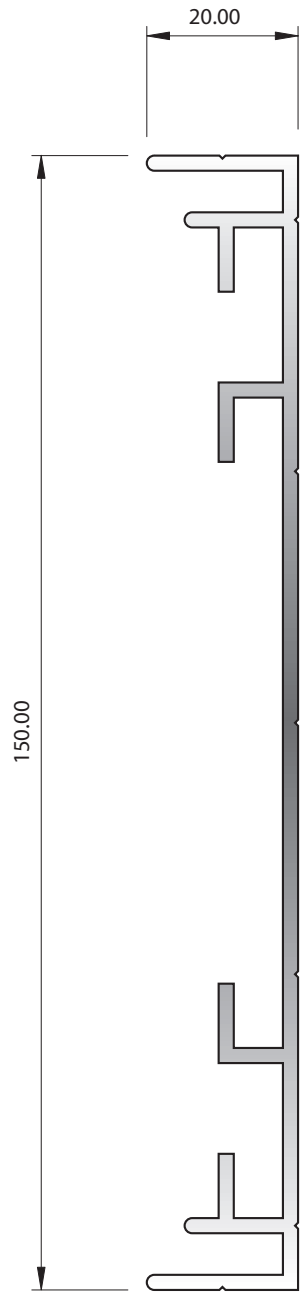

SECTION No. X540
 1.418 kg/m
 P = 528.89

For NZ based customers. All lengths are stocked in 6060 T5 - mill finish - 5m lengths (unless specified)
 All peripheries less than 100mm are deemed 100mm for surface finish purpose

Fence & Balustrade

SECTION NUMBER	SHAPE	MASS kg/m	OUTSIDE PERIM	LENGTH
8333K	BASE PLATE	-	-	-
31292	GATE PLANK	0.968	197.12	5.00
G452	LOUVRE	0.438	211.29	5.60
1229	LOUVRE	0.630	295.78	5.00
32044	LOUVRE	0.679	183.79	5.00
34509	LOUVRE	0.986	243.41	6.00
32507	LOUVRE	1.453	309.37	5.00
G824	TONGUE & GROOVE PANEL	0.671	214.83	6.00
X534	BALUSTER	0.430	90.55	5.00
35579	FENCING TUBE	0.193	62.83	5.00
J412	BALUSTER	0.314	78.30	5.00
36089	50MM BOX JOINTER	1.010	252.82	5.00
36437	LOUVRE FIXING BRACKET	0.695	211.58	5.00
Z357	FENCING RECTANGLE HOLLOW	0.500	156.85	5.00

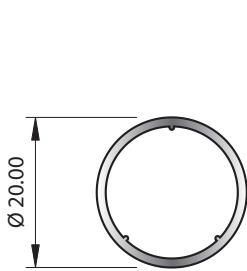

SECTION No. 35579
0.193 kg/m
P = 62.83

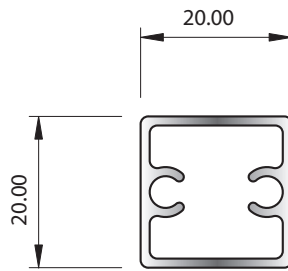

SECTION No. J412
0.314 kg/m
P = 78.30

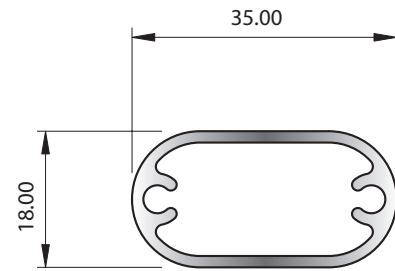

SECTION No. X534
0.430 kg/m
P = 90.55

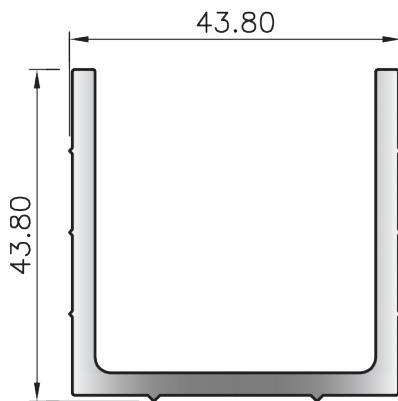

SECTION No. 36089
1.010 kg/m
P = 252.82

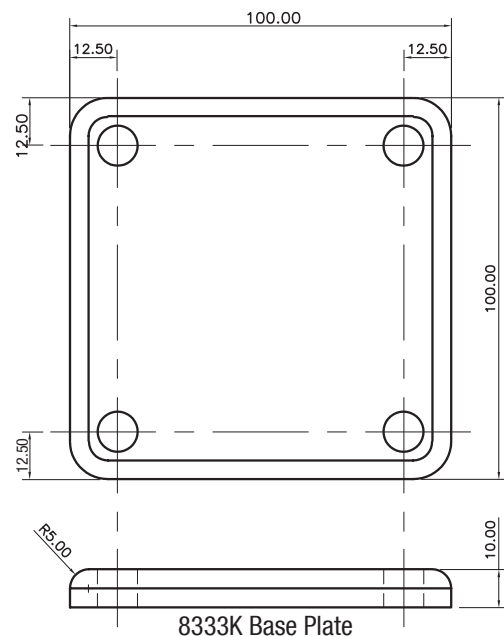

8333K Base Plate

For NZ based customers. All lengths are stocked in 6060 T5 - mill finish - 5m lengths (unless specified)
All peripheries less than 100mm are deemed 100mm for surface finish purpose

Fence & Balustrade

SECTION No. 31292
0.968 kg/m
P = 197.12

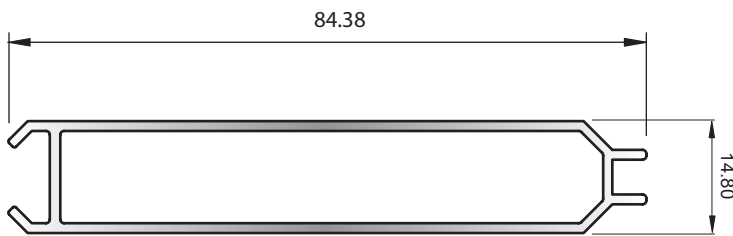
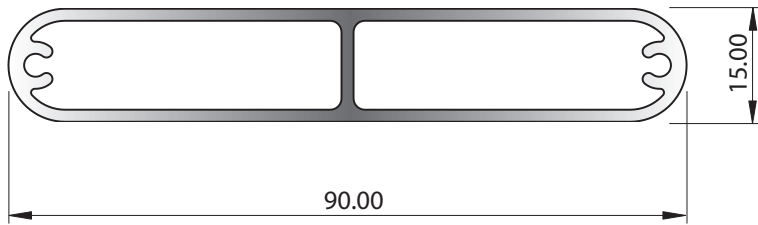

SECTION No. G824
0.671 kg/m
P = 214.83

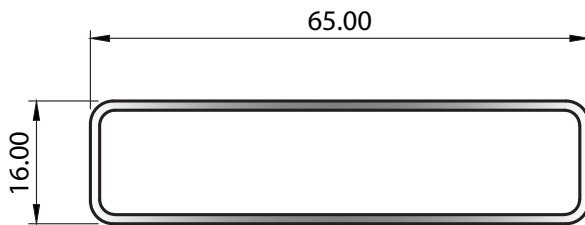

SECTION No. Z357
0.500 kg/m
P = 156.85

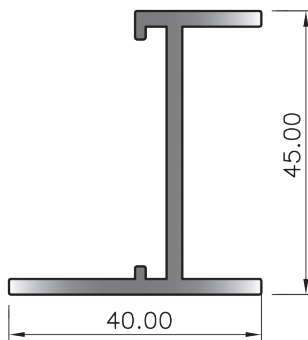

SECTION No. 36437
0.695 kg/m
P = 211.58

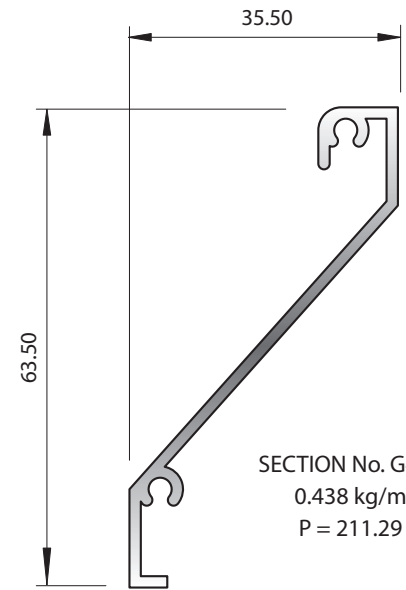

SECTION No. G452
0.438 kg/m
P = 211.29

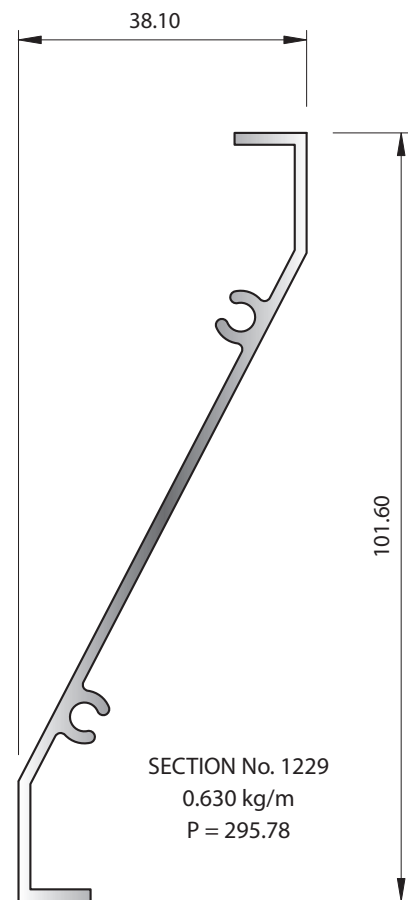

SECTION No. 1229
0.630 kg/m
P = 295.78

For NZ based customers. All lengths are stocked in 6060 T5 - mill finish - 5m lengths (unless specified)
All peripheries less than 100mm are deemed 100mm for surface finish purpose

Fence & Balustrade

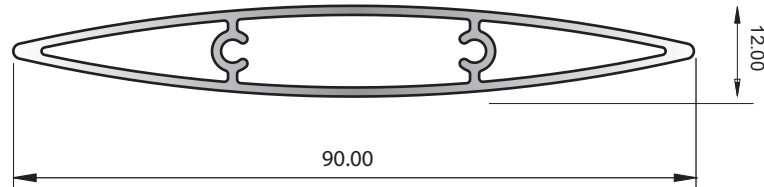

SECTION No. 32044
0.679 kg/m
P = 183.79

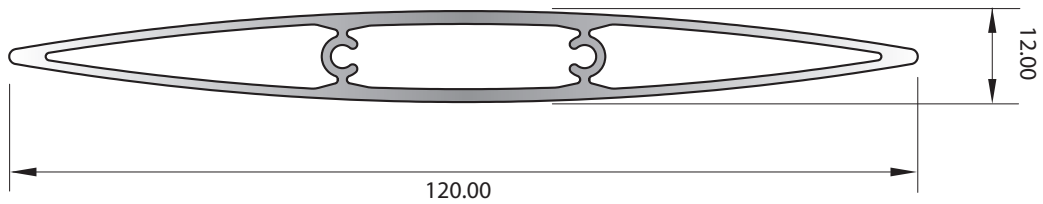

SECTION No. 34509
0.986 kg/m
P = 243.41

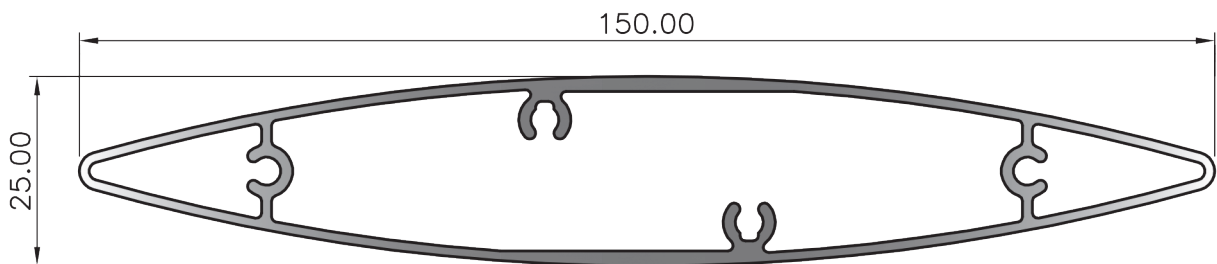

SECTION No. 32507
1.453 kg/m
P = 309.37

For NZ based customers. All lengths are stocked in 6060 T5 - mill finish - 5m lengths (unless specified)
All peripheries less than 100mm are deemed 100mm for surface finish purpose

Index

SECTION NUMBER	PAGE NUMBER	MASS kg/m	OUTSIDE PERIM	SECTION NUMBER	PAGE NUMBER	MASS kg/m	OUTSIDE PERIM
0322	5	0.407	73.00	5014	1	0.703	101.60
0330	54	0.342	88.00	5018	1	2.372	304.80
0340	5	0.326	60.30	5323	2	0.585	150.00
0371	3	0.226	71.10	5424	1	3.485	304.80
0382	3	0.305	115.00	5509	2	0.275	130.00
0460	2	0.388	102.00	5510	1	0.21	100.00
0529	6	1.961	171.50	5511	2	0.188	90.00
0537	5	0.654	69.90	5512	1	0.167	80.00
0572	1	0.753	127.00	5514	2	0.132	64.00
0630	5	0.494	85.80	5581	19 & 23	0.429	181.58
0632	5	0.195	42.60	5584	13	0.987	340.00
0634	5	1.089	88.90	5620	13 & 37	0.484	157.03
0732	13	1.154	181.00	5622	13	1.299	214.50
0749	13	1.171	229.00	5653	13 & 37	0.166	97.50
0757	13	1.932	296.00	5663	44	0.351	143.50
0765	3	0.143	72.80	5706	19 & 23	0.126	77.00
0914	8	1.417	177.80	5728	7	0.301	76.00
1025	1	3.423	402.50	5766	1	0.115	60.00
1184	11	1.284	198.00	5784	6	10.452	355.60
1229	56	0.63	295.78	5854	4	0.942	278.00
1468	7	0.933	177.80	5903	2	0.317	150.00
1478	11	2.123	248.10	5917	7	1.523	200.00
1658	2	1.601	251.06	5931	2	0.286	109.57
1770	3	0.161	79.40	5968	1	0.17	48.00
1864	5	0.384	95.25	5970	2	0.235	64.00
1908	1	5.055	402.48	5971	2	0.275	74.00
2114	4	0.717	183.00	5972	1	0.3	80.00
2386	2	2.085	254.00	5973	1	0.381	100.00
2601	2	3.81	457.20	5974	2	0.437	114.00
3301	6	4.355	279.40	5975	1	0.333	160.00
3882	19	1.569	563.80	5976	1	0.624	160.00
4087	3	0.967	244.00	5977	1	0.786	200.00
4519	11	0.256	124.00	5978	3	0.142	68.80
4575	3	0.559	144.00	5979	3 & 44	0.194	92.80
4760	4	3.915	590.00	5980	3	0.437	114.00
4870	11	0.382	100.00	5982	4	0.599	154.00
4895	19	0.595	278.45	5983	4	0.761	194.00
4954	5	0.325	52.00	5984	4	1.166	294.00
4969	23	0.703	329.25	5985	11	0.166	80.00
4978	6	3.382	147.25	5988	11	0.624	160.00
4989	6	0.62	158.40	5989	5	0.087	43.20
4996	5	0.601	88.20	5991	5	0.13	38.00
5006	1	0.492	127.00	5992	5	0.162	46.00
5009	1	1.21	304.80	5993	5	0.203	56.00
5011	1	0.565	100.60	5994	6	0.405	106.00

For NZ based customers. All lengths are stocked in 6060 T5 - mill finish - 5m lengths (unless specified)
All peripheries less than 100mm are deemed 100mm for surface finish purpose

Index

SECTION NUMBER	PAGE NUMBER	MASS kg/m	OUTSIDE PERIM	SECTION NUMBER	PAGE NUMBER	MASS kg/m	OUTSIDE PERIM
5995	6	0.81	206.00	7955	8	2.252	290.00
5996	5	0.405	62.00	8069	11	2.599	378.30
5997	6	0.81	112.00	8136	19	0.281	157.00
5998	6	1.62	212.00	8163	13	1.732	292.18
5999	5	0.81	74.00	8164	13	2.232	409.78
6076	2	0.462	120.00	8165	13	2.285	363.32
6077	5	0.324	86.00	8166	13	1.325	260.46
6100	13	1.961	313.49	8167	13	0.131	81.99
6136	13 & 44	0.15	72.23	8174	27	0.831	260.61
6179	44	0.45	194.42	8266	2	0.992	250.00
6330	4 & 27	0.37	185.00	8333	6	2.7	220.00
6350	13	0.518	127.00	8459	2	0.252	120.00
6373	6	0.648	166.00	8517	2	0.502	130.00
6421	1	0.1	48.00	8518	1	1.523	200.00
6428	2	0.403	190.00	8521	4	0.616	158.00
6452	4	0.68	174.00	8570	27	0.501	226.56
6476	3	0.801	204.00	8716	4	1.166	294.00
6484	1	0.425	200.00	8776	6	0.972	132.00
6490	8	2.008	260.00	8777	7	0.53	74.85
6558	23	0.977	315.51	8778	7	0.695	94.85
6595	52	0.221	95.94	8950	7	0.3	80.00
6614	7	0.404	100.00	8955	52	0.279	129.99
6669	8	1.626	250.00	8966	54	0.143	47.70
6670	2	0.239	114.00	9056	4 & 27	0.324	203.00
6706	5	0.648	92.00	9193	7	0.647	154.85
6726	19	1.066	387.00	9250	33	0.431	246.63
6788	2	0.988	250.00	9251	33	0.217	136.10
6868K	44	CORNER STAKE		9325	2	0.144	74.00
6868E	44	CORNER STAKE		9328	2	0.205	104.00
6868L	44	CORNER STAKE		9329	2	0.237	120.00
6947	7	0.875	120.00	9335	3	0.31	146.80
6982	4	3.046	387.00	9336	5	0.108	53.20
7040	6	1.296	172.00	9406	8	0.47	120.80
7059	4	3.816	454.00	9433	8	1.118	150.00
7084	2	0.205	104.00	9530	1	1.199	160.00
7414	27	0.62	200.87	9609	7	0.189	50.80
7425	6	1.35	120.00	9675	7	0.346	95.90
7426	5	1.08	100.00	9677	4	0.332	156.80
7652	8	1.691	220.00	9698	23	0.65	254.00
7675	49	0.9	334.00	9699	23	2.914	311.40
7752	19	1.808	318.23	9741	5	0.194	36.00
7754	19	0.267	149.88	9743	1	0.948	240.00
7757	23	0.384	199.13	9745	2	0.397	104.00
7771	19	1.532	240.00	9746	7	1.283	200.00
7789	27 & 54	0.36	118.32	9753	2	0.664	170.00
7841	7	0.596	115.70	9775	49	0.494	150.10

For NZ based customers. All lengths are stocked in 6060 T5 - mill finish - 5m lengths (unless specified)
All peripheries less than 100mm are deemed 100mm for surface finish purpose

Index

SECTION NUMBER	PAGE NUMBER	MASS kg/m	OUTSIDE PERIM	SECTION NUMBER	PAGE NUMBER	MASS kg/m	OUTSIDE PERIM
9777	6	1.944	143.70	32565	7	1.510	194.85
9780	1	1.847	239.50	32605	49	0.540	262.43
9784	7	0.713	99.70	32734^*	7	2.411	193.13
9944	23	2.596	749.11	33133	7	3.004	289.70
9985	8	2.341	300.00	33143	13	1.626	247.85
9987	13	1.617	268.10	33397	7	2.318	294.50
17231	7	4.615	596.57	33423	44	0.744	227.67
30193	2	0.789	200.00	33445	13	0.373	177.47
30196	7	0.811	155.88	33465	3	0.472	122.00
30211	7	0.187	61.25	33479	7	1.022	194.85
30240	8	1.967	251.42	33601	52	0.194	103.12
30299	23	0.399	212.14	33602	37	0.353	178.41
30388	8	5.783	441.42	33603	37	0.278	141.75
30485	8	0.878	120.00	33604	37	0.742	275.99
30486	8	0.493	120.00	33605	37	0.160	91.28
30487	4	0.967	244.00	33627	44	0.483	217.96
30497	8	0.932	180.00	33628	44	0.936	295.94
30543	1	2.341	300.00	33629	44	0.483	217.75
30641	2	1.195	300.00	33630	44	1.200	369.10
30735	4	0.980	247.00	33919	2	3.561	450.00
30752	8	2.307	293.13	33943	5	0.619	100.00
30771	19 & 23	0.511	247.49	33947	33	0.474	118.61
30772	23	0.380	202.94	33952	33	0.293	167.68
30837	8	1.203	229.31	33953	33	0.587	280.10
30957	49	0.302	117.77	33954	33	0.880	392.51
30973	45	0.421	210.39	33955	33	0.220	120.72
31017	49	0.170	98.88	33956	33	0.382	205.55
31018	49	0.139	81.16	33957	33	0.543	290.37
31043	2	0.545	140.00	33958	33	0.391	140.03
31117	11	2.357	293.99	33959	33	0.592	292.46
31292	56	0.968	197.12	33960	33	0.516	199.03
31300	8	1.056	250.00	33972	6	2.033	310.00
31346	27	0.714	355.15	34033	2	0.951	240.00
31347	27	0.614	304.48	34048	8	3.079	300.00
31348	27	0.511	255.15	34049	52	1.253	256.29
31350	7	0.990	189.01	34050	54	0.809	304.98
31442	8	1.526	198.28	34069+	33	0.459	91.18
31465	27	0.325	160.14	34132	41	0.731	286.27
31701	44	0.589	230.62	34244	41	0.501	222.81
31708	1	3.154	400.00	34245	41	0.155	95.43
31882	13	2.072	384.15	34406	8	0.751	144.85
31966	49	0.515	156.98	34461	41	0.426	220.09
32003	7	1.883	155.71	34462	41	0.346	220.59
32044	56	0.679	183.79	34463	41	0.744	271.28
32507	56	1.453	309.37	34509	56	0.986	243.41
32550	13	0.194	87.28	34559	5	0.244	66.00

For NZ based customers. All lengths are stocked in 6060 T5 - mill finish - 5m lengths (unless specified)
All peripheries less than 100mm are deemed 100mm for surface finish purpose

Index

SECTION NUMBER	PAGE NUMBER	MASS kg/m	OUTSIDE PERIM
34689	44	1.521	453.62
34732	41	0.154	90.09
34733	41	0.132	88.11
34734	41	0.148	86.26
34735	41	0.209	130.26
34736	41	0.194	100.54
34737	41	0.184	100.21
34918	49	0.325	143.76
34987	52	0.496	192.36
35242	54	1.346	503.49
35243	54	1.850	599.95
35300	39	0.429	256.70
35301	39	0.448	267.05
35302*	39	0.464	275.46
35303	39	0.495	251.13
35360	39	0.281	183.89
35361	39	0.298	194.38
35362	39	0.315	204.74
35363	39	0.332	215.09
35364	39	0.348	225.44
35365	39	0.379	235.87
35366	39	0.397	246.26
35367	39	0.530	290.81
35368*	39	0.557	308.24
35369*	39	0.578	319.01
35432	39	0.694	329.92
35469	52	0.561	160.02
35484	39	0.484	287.75
35493	8	0.646	124.85
35511	52	0.382	125.94
35512	52	0.708	211.83
35513	8	4.780	599.31
35579	56	0.193	62.83
35647	13	0.250	118.13
35962	39	0.568	287.13
36058	7	5.129	394.85
36089	4 & 56	1.010	252.82
36116	41	0.163	93.21
36117	41	0.275	155.35
36118	41	0.137	85.96
36119	41	0.154	103.20
36120	41	0.151	93.75
36157	33	0.310	76.58
38959	44	0.115	100.00
36405	44	0.154	87.09
36437	56	0.695	211.58

SECTION NUMBER	PAGE NUMBER	MASS kg/m	OUTSIDE PERIM
36483	41	0.718	285.67
38703	41	0.796	313.05
36814	39	0.597	329.36
37044	8	0.824	160.00
37069†	39	0.617	339.71
37070†	39	0.637	350.07
37080†	39	0.704	360.51
37488	44	0.109	77.13
37523	44	0.804	237.92
37805	11	5.147	397.94
37864	41	0.274	178.09
37866	41	0.167	94.55
37868	41	0.151	101.86
37999	41	0.333	173.66
50212	39	0.525	172.96
50285	39	0.552	209.91
660000	44	DOOR HANDLE - WHITE	
660001	44	DOOR HANDLE - BLACK	
660002	44	5 PIN CYLINDER	
660003	44	3 POINT LOCK KIT	
660004	44	75mm DOOR HINGE - WHITE	
660005	44	75mm DOOR HINGE - BLK	
660006	44	LEICHHARDT SLIDING DOOR LOCK	
660007	44	WHEELS FOR SECURITY DOOR	
660010	44	PATIO BOLT	
660022~	3	0.246	100.00
660023#	3	0.246	100.00
660154	3	0.230	100.00
660155	3	0.230	100.00
661007	44	UBE LOCK	
662107	44	WHEELS FOR 9775 FLYSCREEN DOOR	
MESH	44	2000mm x 750mm	
MESH	44	2000mm x 920mm	
MESH	44	2000mm x 1250mm	
MESH	44	2455mm x 1200mm	
MESH	44	4000mm x 750mm	
MESH	44	4000mm x 1250mm	
E301	6	2.033	262.00
E320	6	5.420	420.00
E709	8	1.626	250.00
E905	8	0.623	150.00
E927	2	2.341	300.00
G058	19	1.057	511.10
G059	19	1.398	505.10

For NZ based customers. All lengths are stocked in 6060 T5 - mill finish - 5m lengths (unless specified)
All peripheries less than 100mm are deemed 100mm for surface finish purpose

Index

SECTION NUMBER	PAGE NUMBER	MASS kg/m	OUTSIDE PERIM	SECTION NUMBER	PAGE NUMBER	MASS kg/m	OUTSIDE PERIM
G060	23	1.295	513.70	J900	6	5.567	192.20
G061	23	1.531	604.65	K011	8	1.252	202.00
G062	19 & 23	0.579	280.67	K014	1	0.254	128.00
G083	19	0.927	422.42	K024	5	0.184	98.10
G097	7	0.824	160.00	K068	33	0.564	266.60
G210	3	0.698	211.00	K102~	8	4.348	286.27
G249	13	1.510	331.00	K129	1	0.824	160.00
G250	13	1.470	285.12	K132	7	0.801	189.90
G251	13	1.400	484.40	K308	7	1.694	260.00
G252	23	2.828	576.60	K323	7	2.341	300.00
G253	44	0.500	194.49	K362	7	0.650	128.00
G419	13	1.914	436.36	K496	8	0.308	98.20
G452	56	0.438	211.29	K574	27	0.287	157.90
G466	1	0.132	64.00	K582	8	0.661	130.00
G589	8	2.585	330.00	K803	44	0.158	87.40
G611	13	1.998	421.05	K804	44	0.106	56.70
G677	7	0.498	131.31	K805	44	0.116	62.50
G705	8	1.366	180.00	K910	8	1.854	240.00
G743	4	0.634	161.48	K911	7	0.666	160.00
G824	56	0.671	214.83	N285	7	0.432	94.85
G902	11 & 27	1.078	444.57	N452	23	1.519	505.40
HX0111*	11	0.290	38.46	N737	7	1.185	154.85
J007D	44	1.022	320.58	N923	33	0.37	230.10
J030	49	0.496	199.00	N924	33	0.745	409.90
J031	49	0.191	94.00	RD0063	9	0.086	19.95
J032	49	0.234	118.00	RD0095	9	0.193	29.94
J058	49	0.232	94.71	RD0120~	9	0.306	37.70
J074	2	0.341	90.00	RD0127	9	0.342	39.90
J088	3	0.618	158.00	RD0159	9	0.537	49.89
J089	4	1.577	394.00	RD0160	9	0.545	50.30
J090	8	1.528	200.00	RD0190	9	0.769	59.85
J105	2	0.585	220.00	RD0200*	9	0.851	62.80
J168	3	0.116	56.80	RD0222	9	1.052	69.84
J169	7	0.943	128.00	RD0254	9	1.375	79.80
J309	7	0.840	200.00	RD0270	9	1.555	84.80
J403	6	0.488	126.00	RD0317	9	2.138	99.75
J412	56	0.314	78.30	RD0349	9	2.587	109.74
J456	2	0.278	140.00	RD0381	9	3.078	119.69
J458	4	1.252	314.00	RD0445	9	4.190	139.64
J712	6	0.433	203.20	RD0500	9	5.321	157.08
J723	6	0.347	163.20	RD0508	9	5.472	159.59
J781	5	0.082	26.00	RD0520	9	5.755	163.36
J791	5	0.097	30.00	RD0540	9	6.206	169.65
J792	1	1.040	200.00	RD0571	9	6.926	179.54
J845	8	1.583	300.00	RD0603	9	7.715	189.50
J863	8	3.154	400.00				

For NZ based customers. All lengths are stocked in 6060 T5 - mill finish - 5m lengths (unless specified)
All peripheries less than 100mm are deemed 100mm for surface finish purpose

Index

SECTION NUMBER	PAGE NUMBER	MASS kg/m	OUTSIDE PERIM	SECTION NUMBER	PAGE NUMBER	MASS kg/m	OUTSIDE PERIM
RD0699	9	10.361	219.59	TU8640	10	1.216	159.60
RD0762	9	12.313	239.40	TU8650	10	1.374	179.10
RD0889	9	16.76	279.29	TU8651	10	1.959	251.30
RD1016	9	21.89	319.19	TU8655	10	2.478	314.20
RD1270	9	34.32	398.98	TU8720	10	1.661	199.50
SQ0064	11	0.109	25.40	TU8780	10	1.666	152.10
SQ0100	11	0.271	40.00	X075	3 & 49	0.162	98.63
SQ0120	11	0.390	48.00	X076	49	0.119	79.33
SQ0160	11	0.694	64.00	X124G	44	CORNER STAKE	
SQ0200	11	1.084	80.00	X124L	44	CORNER STAKE	
SQ0250	11	1.694	100.00	X190	6	1.014	158.23
SQ0318*	11	2.721	127.00	X389	49	0.139	71.64
SQ0381*	11	3.919	152.40	X510	8	0.622	120.85
SQ0445*	11	5.335	177.80	X534	56	0.430	90.55
TU8014	10	0.151	50.30	X540^	55	1.418	528.89
TU8020	10	0.152	49.90	X544	8	1.101	144.85
TU8030	10	0.185	59.80	X549	7	1.621	198.05
TU8035	10	0.217	69.80	X550~	7	4.434	277.50
TU8090	10	0.098	29.90	X574	44	0.249	126.32
TU8110	10	0.136	39.90	X592**	7	1.203	160.00
TU8120	10	0.174	49.90	Z120	6	1.355	210.00
TU8140	10	0.213	59.80	Z320	7	3.154	400.00
TU8160	10	0.290	79.80	Z335	8	3.960	500.00
TU8170	10	0.327	89.80	Z340	44	0.751	240.51
TU8180	10	0.366	99.70	Z357	8 & 58	0.500	156.85
TU8190	10	0.443	119.70	Z381	27	0.769	279.34
TU8218	10	0.300	78.50	Z382	27	1.326	428.12
TU8240	10 & 52	0.251	62.80	Z383*	27	0.953	328.12
TU8260~	10	0.197	49.90	Z439	33	0.285	106.40
TU8290	10	0.284	39.80	Z447*	33	0.282	165.46
TU8440	10	0.390	78.50	Z661	37	0.184	114.92
TU8441	10	0.647	125.70	Z662	37	0.442	207.66
TU8442	10	0.723	139.60	Z785	44	0.748	240.25
TU8443	10	0.817	157.08	Z912	7	0.887	238.28
TU8447	10	1.047	199.49	Z913	8	0.659	178.28
TU8523	10	0.724	119.70	Z965	2	0.470	220.00
TU8524	10	0.868	136.03	Z965	2	0.470	220.00
TU8530	10	0.297	49.90				
TU8555	10	1.014	152.10				
TU8575!	10 & 52	0.562	78.50				
TU8580	10	0.573	79.80				
TU8601	10	0.741	100.50				
TU8610	10	0.896	119.70				
TU8615	10	0.942	125.70				
TU8620	10	1.059	139.60				
TU8630	10	1.196	157.10				

For NZ based customers. All lengths are stocked in 6060 T5 - mill finish - 5m lengths (unless specified)
All peripheries less than 100mm are deemed 100mm for surface finish purpose



McKechnie[®]
Transforming Aluminium

www.mckechnie.co.nz

FOR ORDERS & ENQUIRIES CALL CUSTOMER SERVICES:

Stocked Product & Standard Geometric Shapes/Sections

Freephone: 0800 625 111

Email: distribution@mckechnie.co.nz

Mill & Fabrication

Freephone: 0800 625 000